

Date Purchased _____ Machine Serial No. _____

Options _____

The key number system in this parts book is arranged as follows:

- ◎ - Key numbers with two circles denotes main assemblies.
- - Key numbers with one circle are individual parts

Please order parts by number

**EURO REEL ▪ 198-00-00-000****PRE OPERATION CHECKLIST:**

1. Ensure all hydraulic hoses and fittings are in good condition.
2. Check wheel nut tension and tire pressure.
3. Check chain tension and adjust if necessary.
4. Apply grease to all grease fittings.
5. Check field for any sharp objects.

OPERATING INSTRUCTIONS:

1. Stop tractor before attempting to service machine in any way.
2. Reel must be attached to Tractor while in operation. Always apply brakes while reeling in, and an operator must be present in tractor at all times while the reel is winding in/out.
3. Never try and wind up more than 660 feet of hose on one pull. Never try to pull a full hose, ensure hose is empty before pulling in.
4. Always back the Husky Hose Reel up to get a few wraps around hose drum before pulling hose tight, otherwise it will pull the end off of the hose.
5. While spreading/injecting the manure always make tight turns with tractor. If too wide a turn is made, hose may flip over and coil up.
6. When spreading manure with drag hose always have an operator at high pressure pump to shut down if hose breaks, or have a radio controlled kill switch on pump tractor to avoid spills.
7. If spill does occur and there is a danger that water ways will be contaminated, contact authorities **Immediately**, they will help direct the clean up. In Canada call 1-800-268-6060
8. Never enter a tanker without special breathing equipment to supply oxygen. **Manure gas can Kill** instantly. One breath of Hydrogen Sulphide can Kill.

FRONT VIEW OF EURO REEL

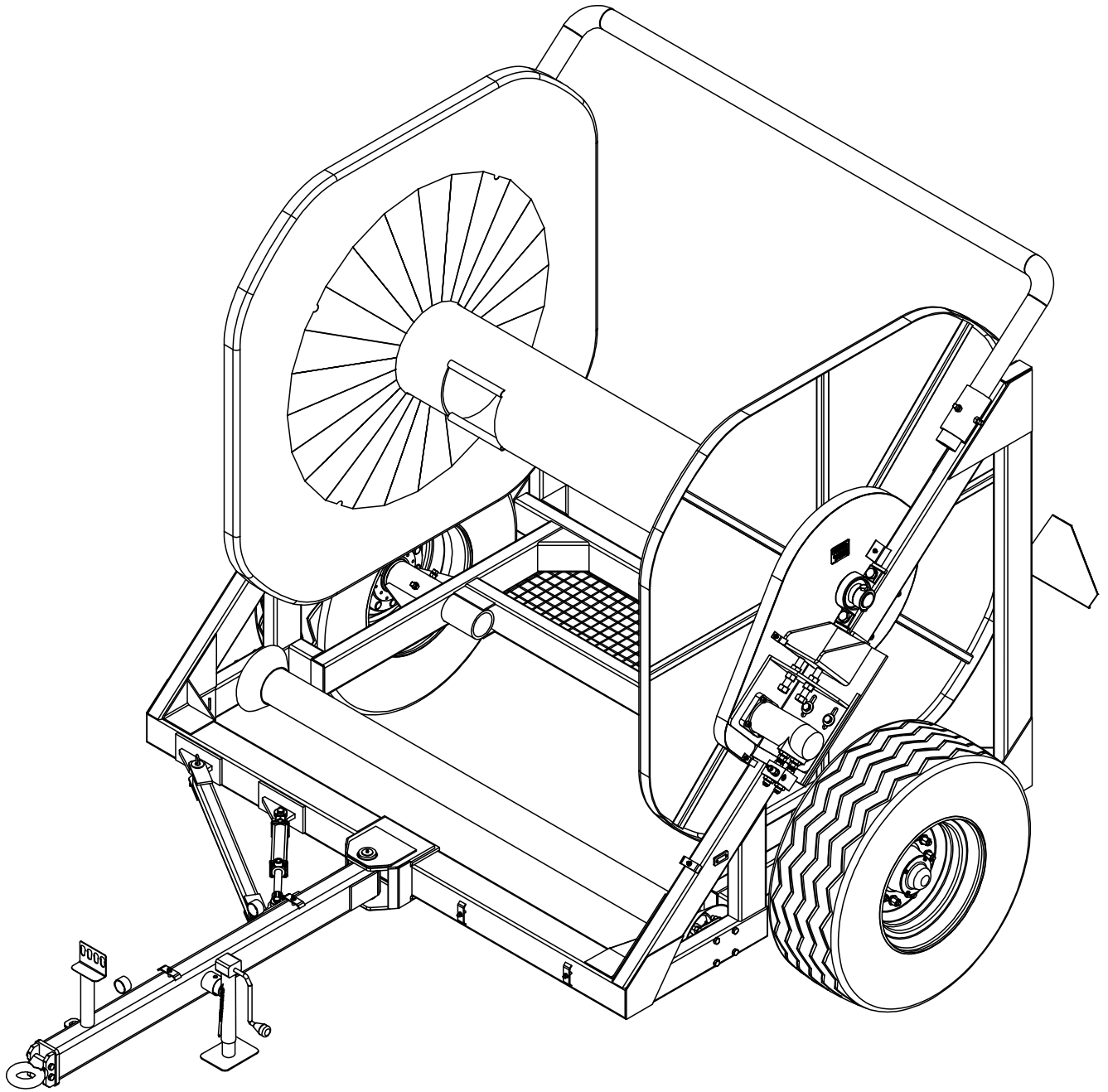

REAR VIEW OF EURO REEL

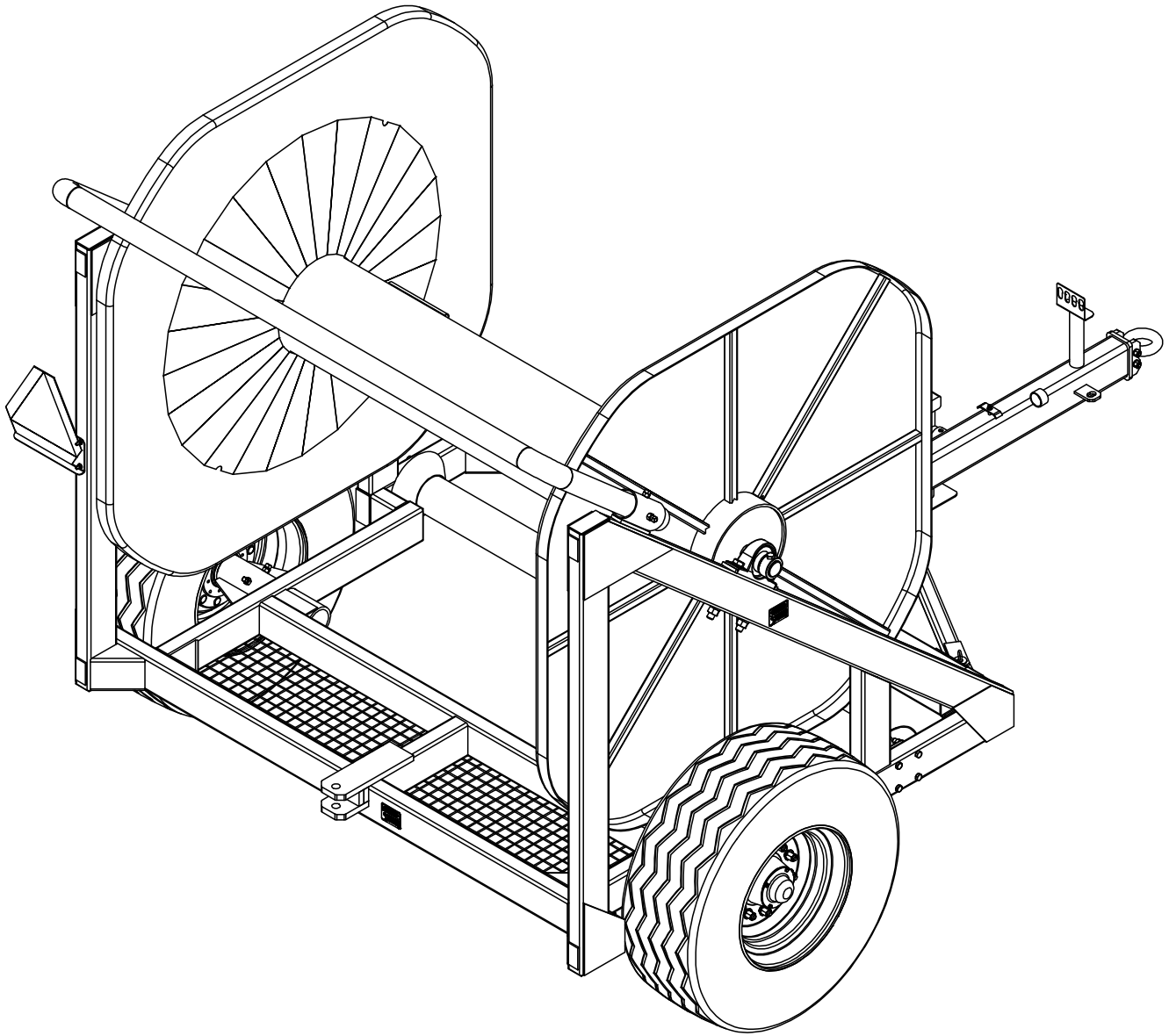

FRAME ASSY

DECALS



R09758 - ROTATING MACHINERY DECAL



R09582 - GREASE DECAL



R09071 - SERIAL NUMBER PLATE



R08152 - 6 x 1/4" PAN HD SOCKET SCREW

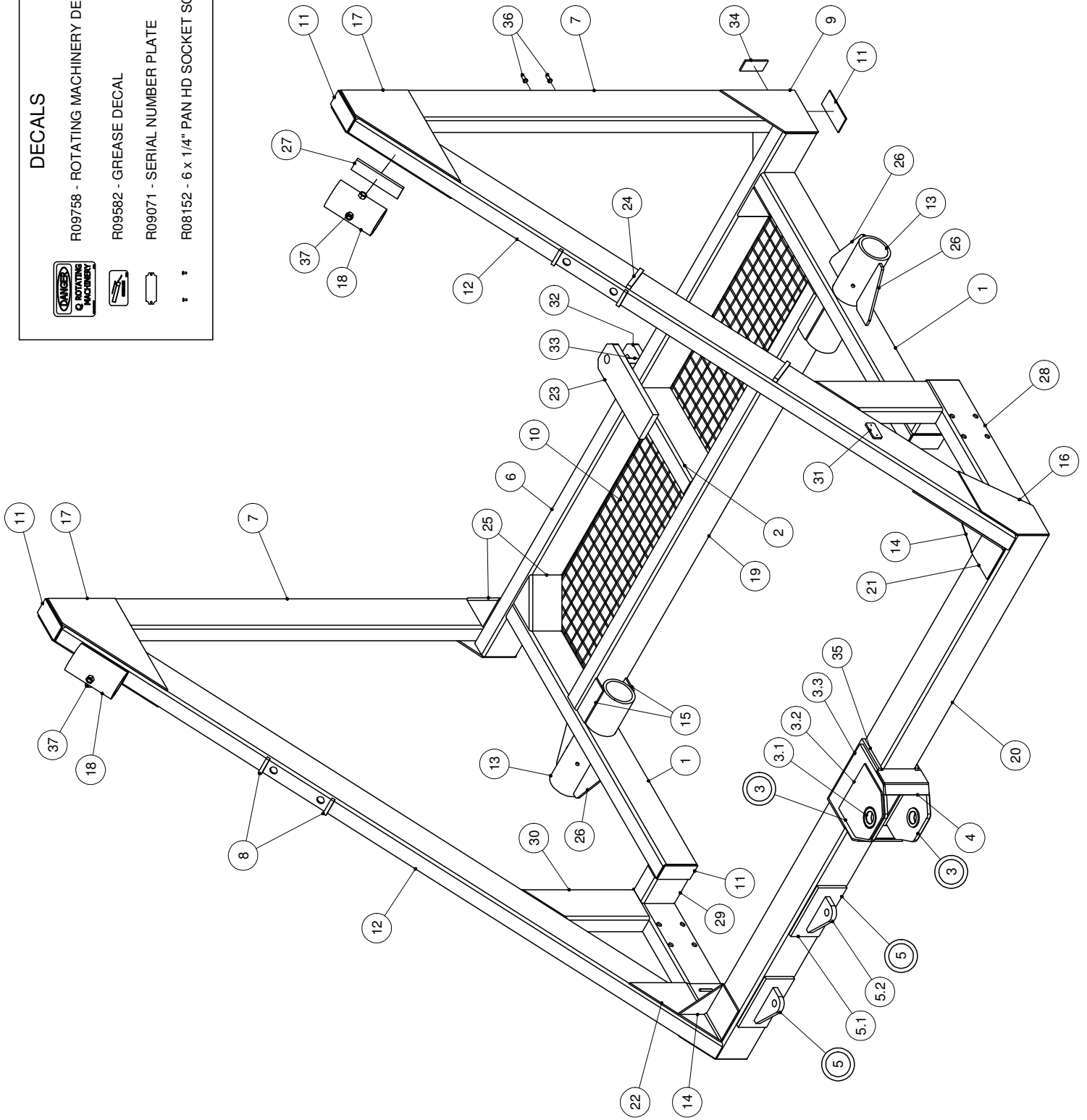

FRAME ASSY

PARTS LIST			
ITEM	PART NUMBER	DESCRIPTION	QTY
1	198-02-00-011	FRAME SIDE	2
2	198-02-00-014	CENTER BEAM	1
3	198-02-06-000	TONGUE PLATE ASSY	2
3.1	200-01-01-005	TOGUE PLATE SLEEVE	1
3.2	200-01-01-268	REINFORCING PLATE	1
3.3	198-02-06-072	TONGUE PLATE	1
4	198-02-00-073	TONGUE PLATE REINF. PC	2
5	200-37-02-000	CYLINDER LUG ASSY	2
5.1	200-37-02-248	LUG BASE PLATE	1
5.2	200-37-02-249	CYLINDER LUG	1
6	198-02-00-013	FRAME REAR TUBE	1
7	198-02-00-015	REAR VERTICAL TUBE	2
8	204-10-05-119	BRG STOP BLOCK	4
9	198-02-00-025	REAR CORNER GUSSET	2
10	198-02-00-020	CAGE	1
11	198-02-00-026	END CAP	8
12	198-02-00-016	ANGLED BRG HOLDER TUBE	2
13	198-02-00-018	SPINDLE SLEEVE	2
14	198-02-00-023	CORNER GUSSET	2
15	198-02-00-028	SPINDLE SLEEVE GUSSET	4
16	198-02-00-024	FISH PLATE	2
17	198-02-00-027	TOP TUBE GUSSET	4
18	198-02-00-017	OUTER SLEEVE	2
19	198-02-00-012	FRAME CENTER TUBE	1
20	198-02-00-010	FRAME CROSS BEAM	1
21	198-02-00-022	LH TIE GUSSET	1
22	198-02-00-021	RH TIE GUSSET	1
23	204-01-00-005	REAR HITCH PLATE	1
24	198-02-00-029	TIGHTENER KIT STOPS	2
25	198-02-00-019	FORMED CORNER GUSSET	6
26	198-02-00-050	SPINDLE SLEEVE STIFFENER	4
27	198-02-00-058	OUTER SLEEVE SPACER BLOCK	2
28	198-02-00-059	FRAME BRG HOLDER TUBE	2
29	198-02-00-060	FRAME STUB TUBE	2
30	198-02-00-061	FRAME VERTICAL ANGLE TUBE	2
31	340-01-00-498	SERIAL NO. BACK PLATE	1
32	198-02-00-065	LOWER HITCH PLATE	1
33	198-02-00-067	HITCH SPACER PLATE	2
34	198-02-00-068	SKID PAD	4
35	198-02-00-071	TONGUE PLATE SPACER BAR	2
36	R07619	3/8 x 1 UNC HEX BOLT	2
37	R07786	5/8-11 UNC HEX NUT	4

REEL ASSY

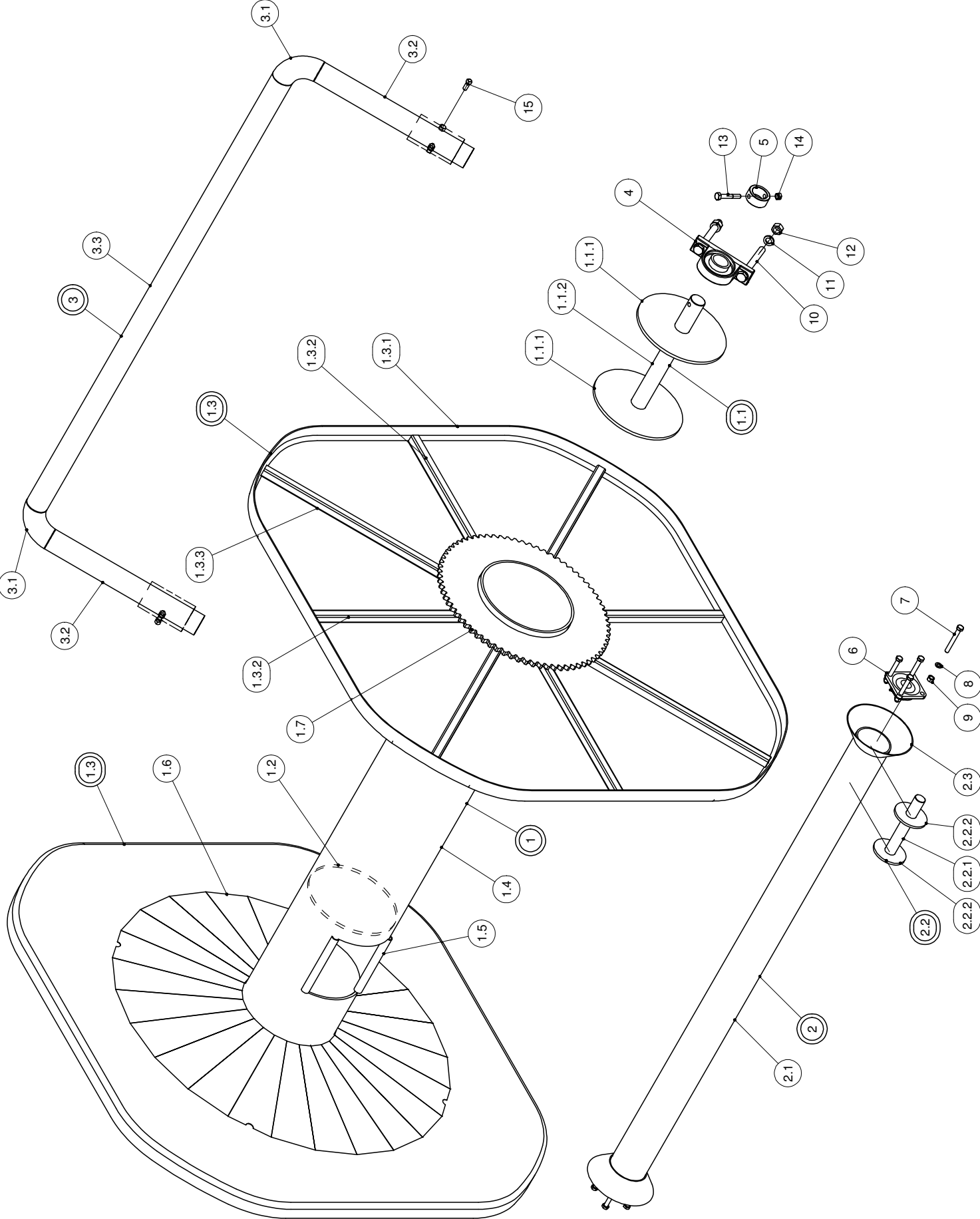

REEL ASSY

PARTS LIST			
ITEM	PART NUMBER	DESCRIPTION	QTY
1	198-01-00-000	OPEN REEL ASSY	1
1.1	198-01-01-000	STUB SHAFT ASSY	2
1.1.1	198-01-01-001	STUB INNER RING	2
1.1.2	198-01-01-002	2 1/2" STUB SHAFT	1
1.2	198-01-00-003	INNER REINFORCING RING	2
1.3	198-01-02-000	REEL END ASSY	2
1.3.1	198-01-02-004	REEL END	1
1.3.2	198-01-02-005	SHORT INNER SPOKE	4
1.3.3	198-01-02-006	LONG INNER SPOKE	4
1.4	198-01-00-007	REEL INNER TUBE	1
1.5	198-01-00-008	HOSE CUSHION	4
1.6	198-01-00-055	CONE GUSSET	4
1.7	R20661	100A-72 T SPROCKET W/ 409.5 ID	1
2	198-04-00-000	HOSE GUIDE ROLLER ASSY	1
2.1	198-04-00-041	HOSE ROLLER TUBE	1
2.2	198-04-01-000	ROLLER STUB ASSY	2
2.2.1	198-04-01-039	ROLLER STUB SHAFT	1
2.2.2	198-04-01-040	ROLLER STUB SHAFT PLATE	2
2.3	198-04-00-042	HOSE GUIDE	2
3	198-03-00-000	ADJUSTABLE HOSE GUARD ASSY	1
3.1	R02448	3" WELD ELBOW	2
3.2	198-03-00-038	HOSE GUARD LEG	2
3.3	198-03-00-037	HOSE GUARD PIPE	1
4	R20469	2 1/2" PILLOW BLOCK BEARING	2
5	204-00-00-122	SHAFT COLLAR	2
6	R20188	1 3/4" - 4 BOLT FLANGE BEARING	2
7	R07652	5/8 x 5 UNC HEX BOLT	8
8	R07806	5/8" LOCK WASHER	8
9	R07786	5/8-11 UNC HEX NUT	8
10	R07859	1 x 9 UNC HEX BOLT	4
11	R07808	1" LOCK WASHER	4
12	R07788	1-8 UNC HEX NUT	4
13	R07651	5/8-11 UNC X 4" HEX BOLT	2
14	R07887	5/8 2 WAY LOCK HEX NUT	2
15	R07927	5/8 x 1 1/2 SQ. HD. SET SCREW	4

HYDRAULIC DRIVE UNIT

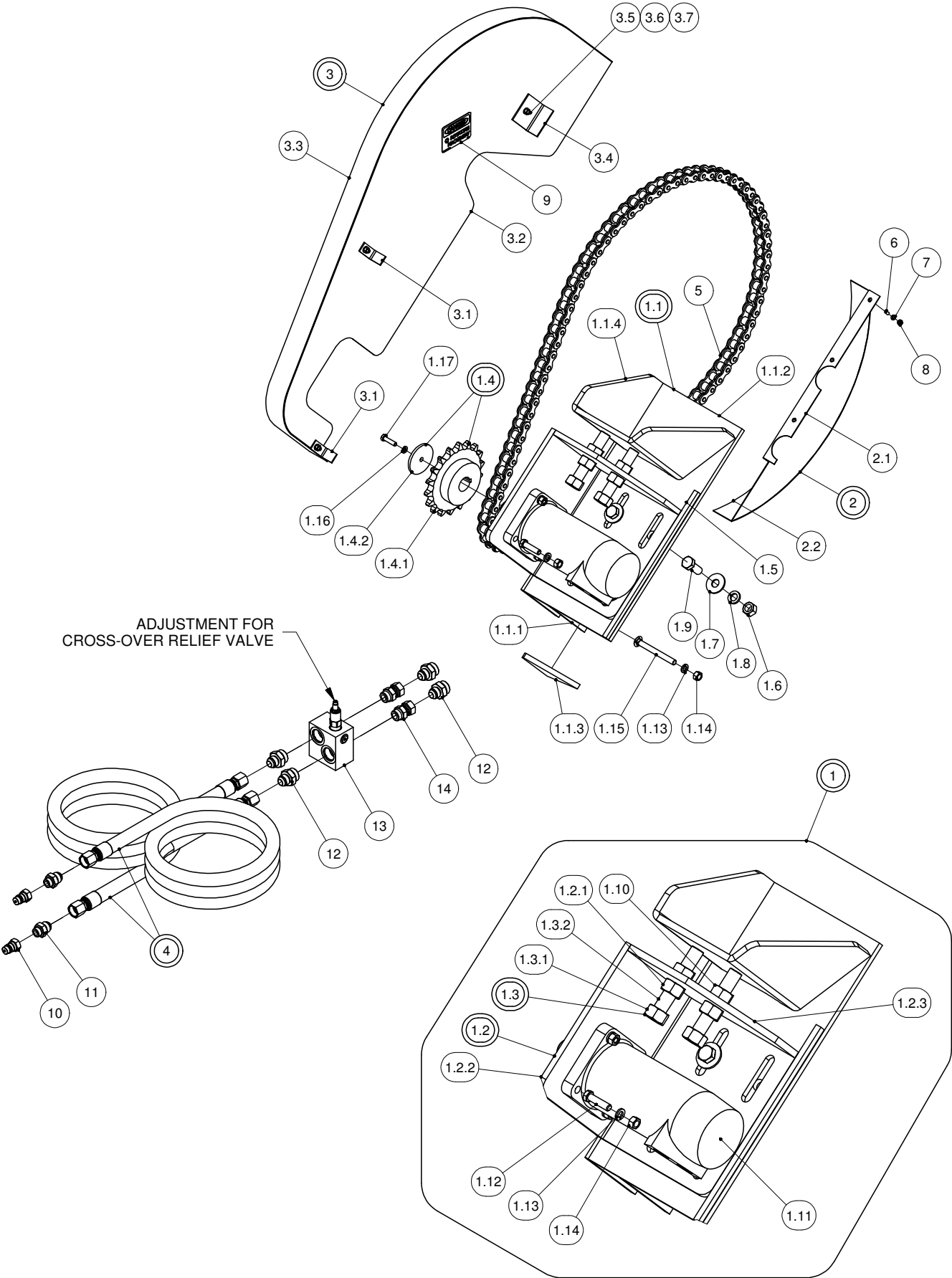

HYDRAULIC DRIVE UNIT

PARTS LIST				PARTS LIST			
ITEM	PART NUMBER	DESCRIPTION	QTY	ITEM	PART NUMBER	DESCRIPTION	QTY
1	198-02-01-000	CHAIN TIGHTENER KIT	1	1.15	R07749	1/2 x 5 UNC CARRIAGE BOLT	4
1.1	198-02-02-000	TIGHTENER BOLT ON ASSY	1	1.16	R07803	3/8" LOCK WASHER	1
1.1.1	198-02-02-031	INNER BOLT ON PLATE	1	1.17	R07620	3/8 x 1 1/2 UNC HEX BOLT	1
1.1.2	198-02-02-030	BOLT ON BRKT	1	2	198-07-00-000	LOWER SPROCKET GUARD ASSY	1
1.1.3	198-02-02-032	GUSSET	3	2.1	198-07-00-048	LOWER GUARD PLATE	1
1.1.4	198-02-02-033	TIGHTENER BLOCK	1	2.2	198-07-00-049	LOWER GUARD BAND	1
1.2	198-02-03-000	MOTOR TIGHTENER ASSY	1	3	198-06-00-000	SPROCKET GUARD ASSY	1
1.2.1	R07788	1-8 UNC HEX NUT	2	3.1	198-06-00-047	LH CLIP	2
1.2.2	198-02-03-034	MOTOR MOUNT BASE PLATE	1	3.2	198-06-00-045	GAURD PLATE	1
1.2.3	198-02-03-035	TIGHTNER GUSSET	1	3.3	198-06-00-046	GUARD BAND	1
1.3	198-02-04-000	ADJUSTMENT ROD ASSY	2	3.4	198-06-00-069	GUARD CLIP	1
1.3.1	R07788	1-8 UNC HEX NUT	1	3.5	R07676	5/16 x 3/4 UNC HEX BOLT	3
1.3.2	198-02-04-036	ADJUSTMENT ROD	1	3.6	R07802	5/16" LOCK WASHER	3
1.4	198-02-05-000	100B 18T SPROCKET ASSY	1	3.7	R07782	5/16-18 UNC HEX NUT	3
1.4.1	R20921	100 B 18T SPROCKET	1	4	198-14-00-000	3/4" HYD HOSE ASSY-FULL LENGTH	2
1.4.2	198-02-05-054	SPROCKET RING	1	5	198-00-00-051	#100 MAIN DRIVE CHAIN	1
1.5	198-02-02-070	GUIDE BAR	1	6	R08301	1/4 x 20 UNC x 1/2" WELD STUD	3
1.6	R07787	3/4-10 UNC HEX NUT	4	7	R07801	1/4" LOCK WASHER	3
1.7	R07827	3/4" FLAT WASHER	4	8	R07781	1/4-20 UNC HEX NUT	3
1.8	R07807	3/4" LOCK WASHER	4	9	R09758	DANGER ROTATING MACHINERY DECAL	1
1.9	R07654	3/4 x 2 UNC HEX BOLT	4				
1.10	R07788	1-8 UNC HEX NUT	2	10	R23182	MALE PIONEER TIP-ORB-10	2
1.11	R22267	6000 SERIES HYD MOTOR	1	11	R23105	ORB-10 X 3/4" JIC M. ADAPTER	2
1.12	R07639	1/2 x 2 UNC HEX BOLT	4	12	R23100	ORB-16 X 3/4" JIV M ADAPTOR	4
1.13	R07805	1/2" LOCK WASHER	8	13	R23342	DUAL RELIEF VALVE-CHARLYNN 6000	1
1.14	R07785	1/2-13 UNC HEX NUT	9	14	R23198	ORB-12 x 3/4" JIC F. SW ADAPTER	2

HYDRAULIC TONGUE - PINTLE EYE

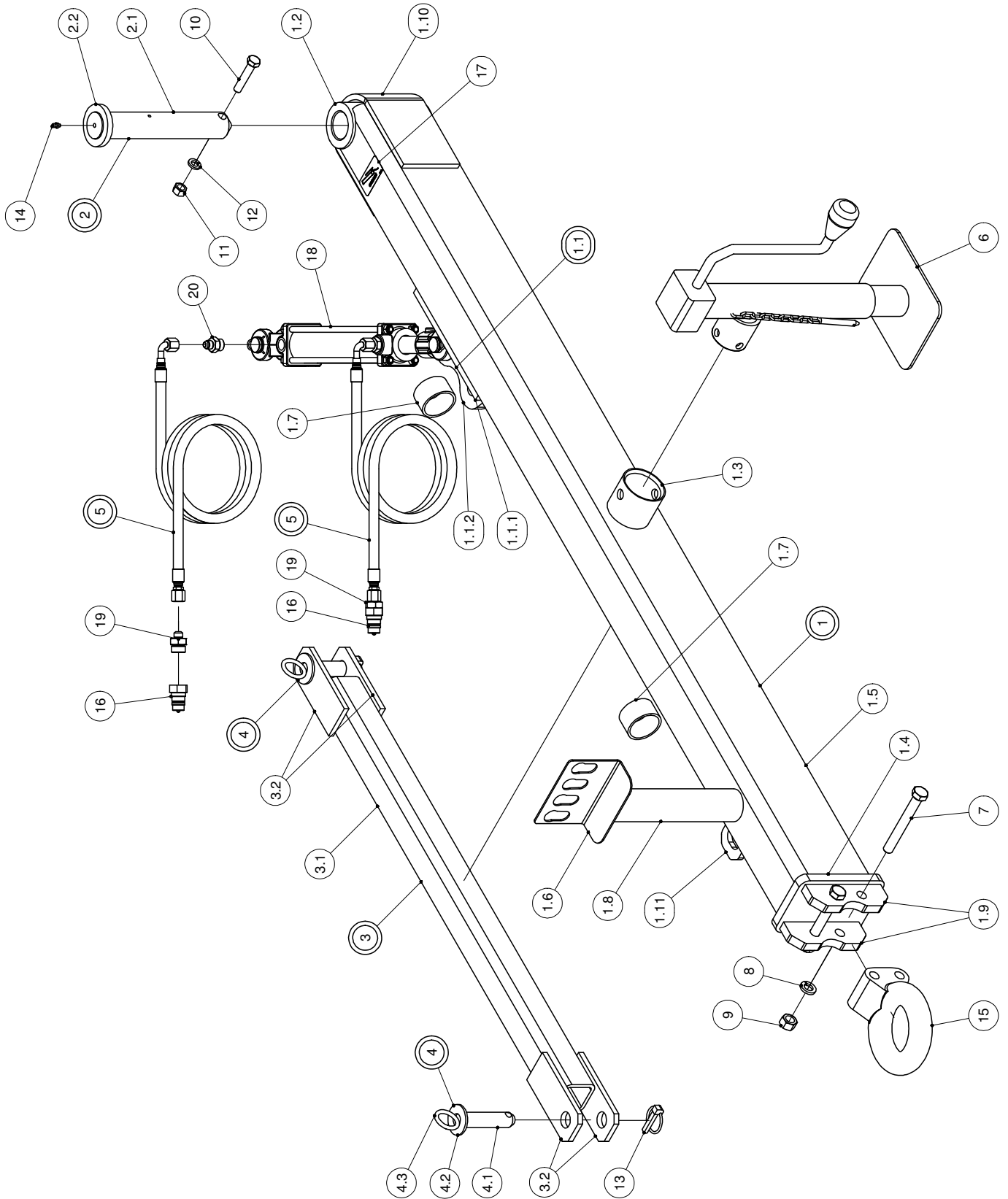

HYDRAULIC TONGUE - PINTLE EYE

PARTS LIST			
ITEM	PART NUMBER	DESCRIPTION	QTY
1	198-05-00-000	TONGUE TUBE ASSY	1
1.1	198-05-01-000	DOUBLE PIN CYLINDER LUG ASSY	1
1.1.1	200-37-02-248	LUG BASE PLATE	1
1.1.2	198-05-01-084	CYLINDER LUG	1
1.2	198-05-00-081	PIVOT SLEEVE	1
1.3	364-35-00-245	TONGUE JACK BRKT	1
1.4	198-05-00-043	HITCH MOUNT PLATE	1
1.5	198-05-00-044	TONGUE TUBE	1
1.6	198-05-00-063	HOSE TIP HOLDER	1
1.7	198-05-00-064	HOSE TUBE	2
1.8	198-05-00-066	HOSE HOLDER TUBE	1
1.9	198-05-00-080	HITCH GUIDE BAR	2
1.10	198-05-00-082	TONGUE TUBE BAND	1
1.11	198-02-00-062	STABILIZER BAR MOUNT BRKT	1
2	200-09-00-000	TONGUE PIN ASSY	1
2.1	200-09-00-042	TONGUE PIN	1
2.2	200-09-00-043	TONGUE PIN WASHER	1
3	200-40-00-000	LONG STABILIZER BAR ASSY	1
3.1	200-40-00-269	LONG STABILIZER BAR	1
3.2	200-40-00-270	STABILIZER BAR BRKT	4
4	200-42-00-000	STABILIZER BAR PIN ASSY-LONG	2
4.1	200-42-00-282	STABILIZER BAR PIN-LONG	1
4.2	R07827	3/4" FLAT WASHER	1
4.3	R07925	1/4 x 1 1/2 PLATED RING	1
5	485-14-00-000	HYD HOSE ASSY-TRACTOR TO REAR OF TIP CYL	2
6	R09751	7000LB SIDE WIND JACK	1
7	R07652	5/8 x 5 UNC HEX BOLT	2
8	R07806	5/8" LOCK WASHER	2
9	R07786	5/8-11 UNC HEX NUT	2
10	R07640	1/2 x 2 1/2 UNC HEX BOLT	1
11	R07785	1/2-13 UNC HEX NUT	1
12	R07805	1/2" LOCK WASHER	1
13	R08040	2 - 18 LYNCH PIN	2
14	R08183	1/4" - 28 STRAIGHT GREASE FITTING	1
15	R10567	3" PINTLE EYE ONLY HITCH	1
16	R21342	1/2" MALE PIONEER TIP	2
17	R09582	GREASE SYMBOL DECAL	1
18	R23267	20TH08 HYD CYL-ORB	1
19	R23094	ORB-10 x 3/8" JIC M ADAPTOR	2
20	R23091	ORB-8 X 3/8" JIC M ADAPTOR	2

TIRE AND WHEEL

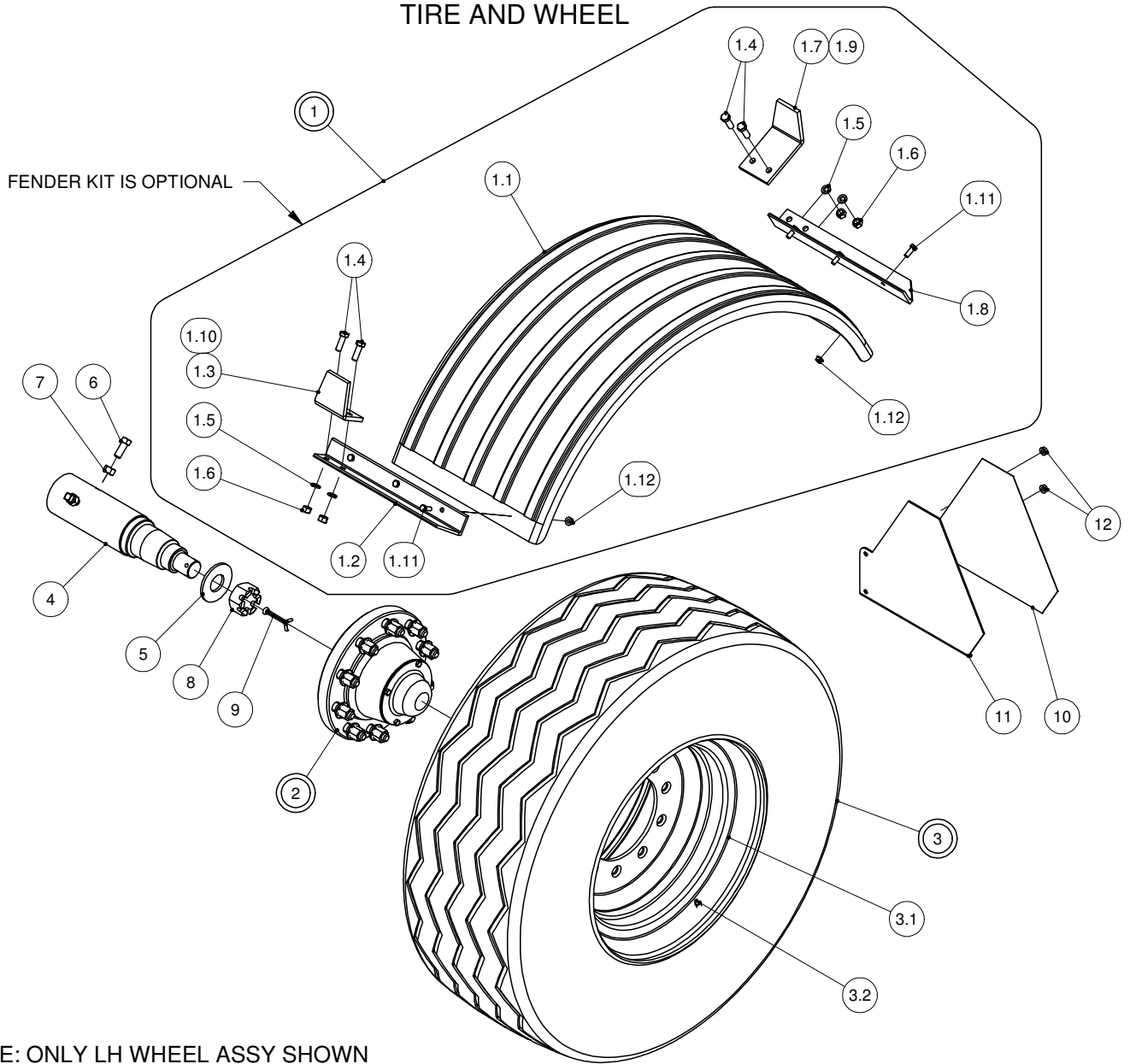

NOTE: ONLY LH WHEEL ASSY SHOWN

PARTS LIST				PARTS LIST			
ITEM	PART NUMBER	DESCRIPTION	QTY	ITEM	PART NUMBER	DESCRIPTION	QTY
1	198-13-00-000	FENDER KIT-RH & LH	1	3	R20010	16 x 22.5 RE-TREAD TIRE & WHEEL ASSY	2
1.1	R22097	POLY FENDER #1901B 19.5 WH	2	3.1	R20059	10 BOLT WHEEL 13.5 x 22.5	1
1.2	198-00-00-076	FENDER ANGLE LH	2	3.2	R20050	VALVE STEM FOR TRUCK TIRE	1
1.3	198-02-00-078	FENDER BRKT-LH FRONT	1	4	340-00-00-347	16000 SPINDLE	2
1.4	R07638	1/2 x 1 1/2 UNC HEX BOLT	8	5	340-00-00-556	1 13/16 SPINDLE WASHER	2
1.5	R07805	1/2" LOCK WASHER	8	6	R07927	5/8 x 1 1/2 SQ. HD. SET SCREW	4
1.6	R07785	1/2-13 UNC HEX NUT	8	7	R07786	5/8 HEX NUT	4
1.7	198-02-00-079	FENDER BRKT-LH REAR	1	8	R20092	1 3/4 - 12 UNF SPINDLE NUT	2
1.8	198-00-00-074	FENDER ANGLE RH	2	9	R20095	5/16" x 4" COTTER PIN	2
1.9	198-02-00-077	FENDER BRKT-RH REAR	1	10	R09501	SLOW MOVING VEHICLE DECAL	1
1.10	198-02-00-075	FENDER BRKT-RH FRONT	1	11	198-00-00-083	S.M.V. SIGN HOLDER	1
1.11	R07619	3/8 x 1 UNC HEX BOLT	12	12	R07794	3/8-16 UNC FLANGE NUT	2
1.12	R07794	3/8-16 UNC FLANGE NUT	12				
2	358-11-00-000	16000LB DUCTILE HUB KIT	2				

16000LB HUB ASSY

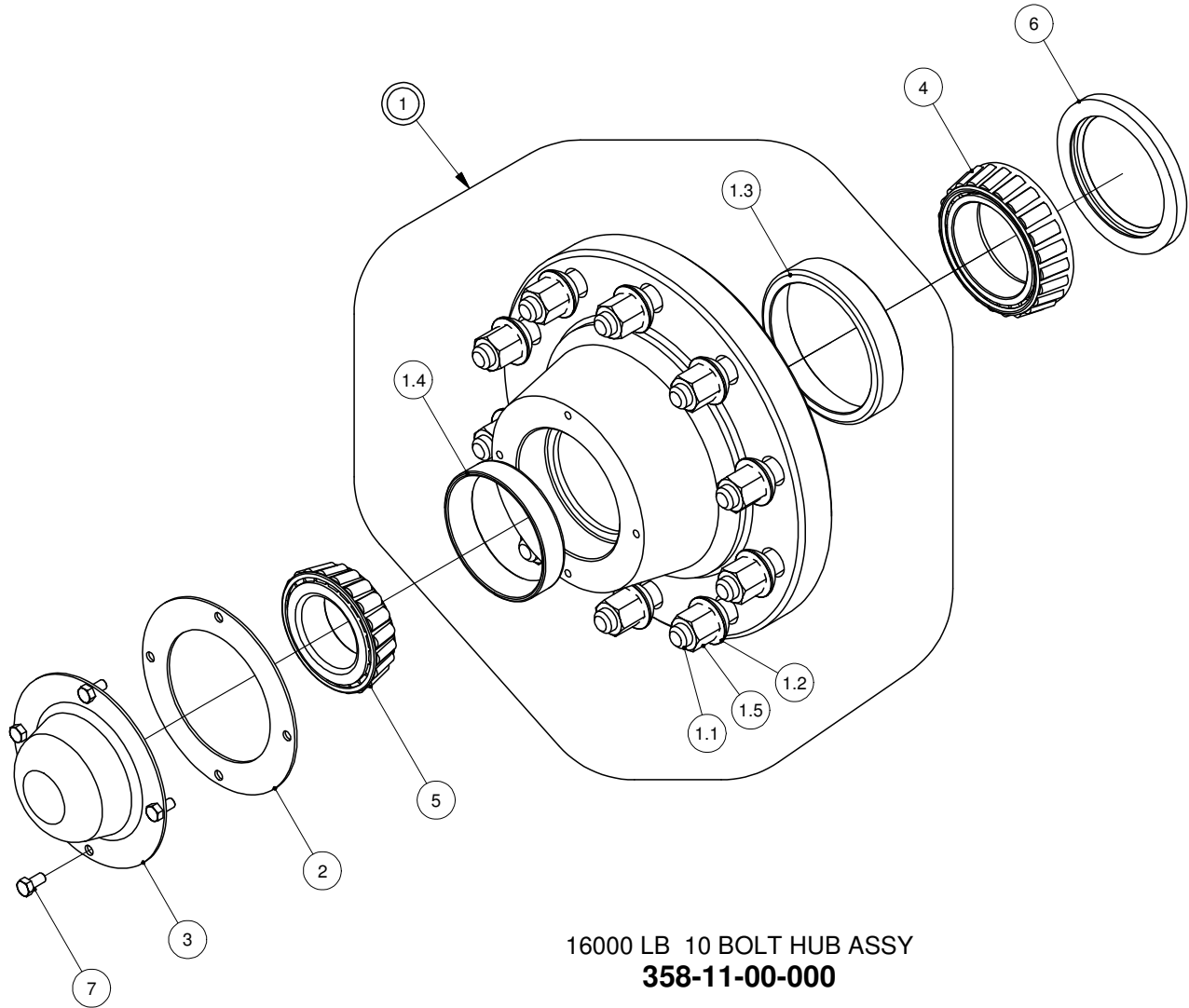

**16000 LB 10 BOLT HUB ASSY
358-11-00-000**

PARTS LIST			
ITEM	PART NUMBER	DESCRIPTION	QTY
1	358-11-00-259	16000LB DUCTILE HUB W/CUPS	1
1.1	R20096	3/4" WHEEL BOLTS	10
1.2	R20152	3/4" SPHERICAL WASHER	10
1.3	R20088	47620 INNER CUP	1
1.4	R20089	39520 OUTER CUP	1
1.5	R07820	3/4" FED. HIGH HEX NUT	10
2	R20084	DUST CAP GASKET. 10 BOLT	1
3	R20093	DUST CAP - 16000 LB HUB	1
4	R20086	476871 3 1/4" INNER CONE	1
5	R20087	39585 2 1/2" OUTER CONE	1
6	R20083	CR-38730 HUB SEAL	1
7	R07690	5/16 x 5/8 HEX BOLT	4

GUARANTEE

All Husky Farm Equipment manufactured by Husky Farm Equipment Limited is guaranteed. Guarantee covers all the replacement cost or repair of all parts said to be defective from manufacture. Guarantee also covers labour installing said parts, if installed at Husky Manufacturing plant. Time and use is the essence of the guarantee. If equipment is used on a private property for an individual's use, guarantee will be in effect for twelve months from date of invoice. If equipment is used for commercial use to do custom work for money then guarantee will be in effect for three months only from date of invoice.

EXEMPTIONS FROM GUARANTEE

Cost of transportation of equipment to or from Husky Farm Equipment Limited either by customer or by Husky's service staff or cost of mail or public transportation is not covered. Tires and electric or hydraulic motors are covered by manufacturer's warranty and although Husky may assist to get warranty, Husky will not be responsible other than that allowed by manufacturer's warranty. Items subject to normal wear from use not covered by guarantee if faulty part is simply worn.