

Office Copy

10/20/2005 - 16 made  
Nov 11/06 - 5"

# HUSKY FARM EQUIPMENT LIMITED

## SOFT HOSE REEL PARTS BOOK & OPERATING INSTRUCTIONS

Date Purchased \_\_\_\_\_ Machine Serial # \_\_\_\_\_

### HUSKY DRAG HOSE REEL 7 HOSE STYLE 200-00-00-000

**PLEASE NOTE:**

**Pre Operation Checklist:**

- Ensure all hydraulic hoses and fittings are in good condition.
- Adjust spring loaded brake, so that enough tension is applied as hose unreels. A lack of tension may cause the reel to unwind uncontrollably
- Check wheel nut tension, and tire pressure.
- Check chain tension, and adjust if necessary. Apply grease to all grease fittings.
- Check field for any sharp objects

**Operating Instructions:**

- Stop tractor before attempting to service machine in any way.
- Reel must be attached to Tractor while in operation. Always apply brakes while reeling in, and an operator must be present in tractor at all times while the reel is winding in/out
- For free wheeling, tie hose to a stationary object and remove free wheeling pin, then drive tractor ahead slowly as the hose unreels.
- Never try to reel up more than 660 feet of hose on one pull. Never try to pull a full hose, ensure hose is empty before pulling in.
- Always back the Husky Hose Reel up to get a few wraps around hose drum before pulling hose tight, otherwise it will pull the end off of the hose.
- While spreading/injecting the manure always make tight turns with tractor. If too wide a turn is made, hose may flip over and coil up.
- When spreading manure with drag hose always have an operator at high pressure pump to shut unit down if hose breaks, or have a radio controlled kill switch on pump tractor to avoid spills.
- If spill does occur and there is a danger that water ways will be contaminated, contact authorities **Immediately**, they will help direct the clean up. In Canada call 1-800-268-6060.
- Always beware of manure gas, never enter a manure tank. **"Gas can Kill"**.

# 7 REEL FRAME ASSY

7 HOSE REEL FRAME ASSY  
200-41-00-000

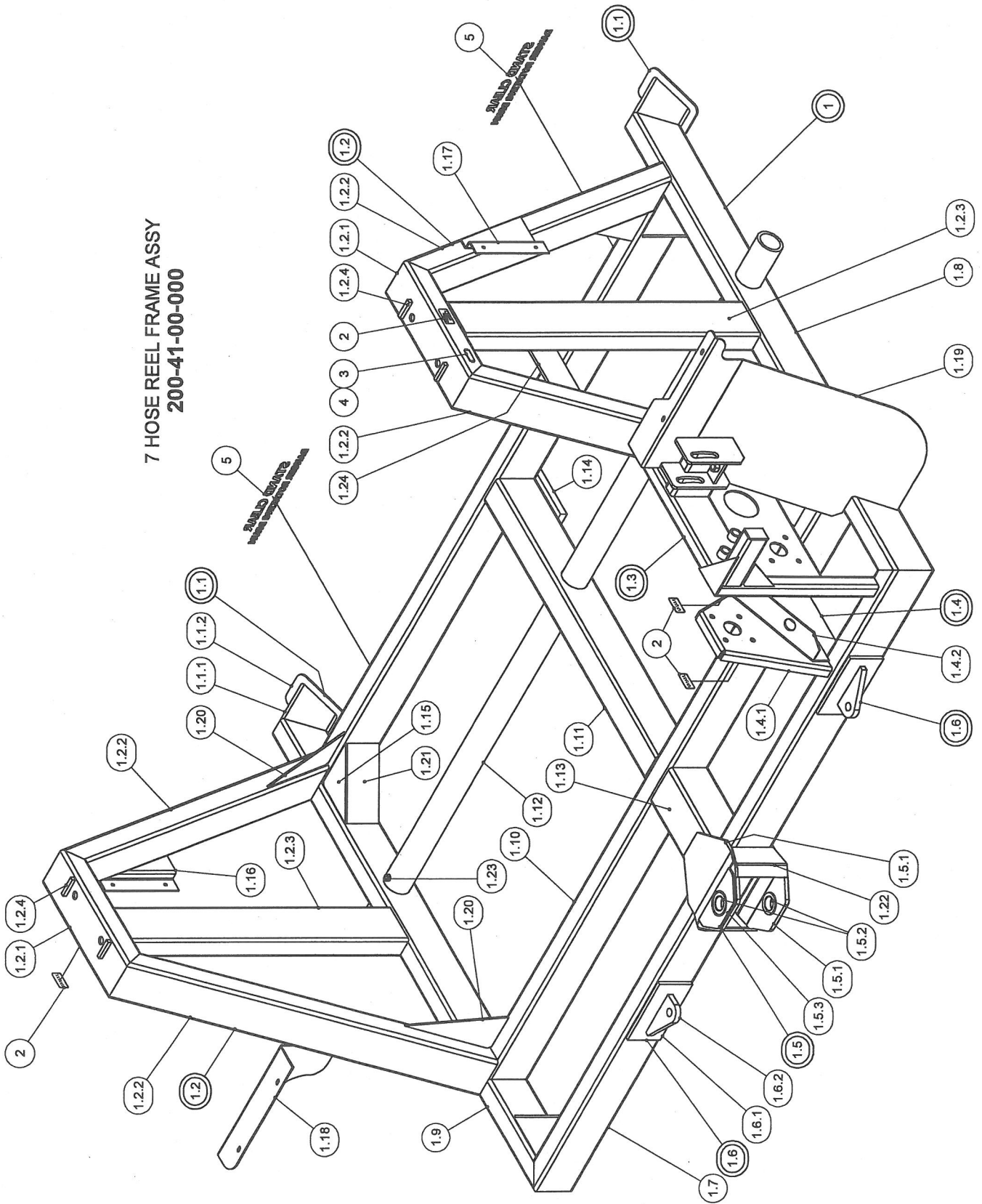

## 7 REEL FRAME ASSY

PARTS LIST			
ITEM	PART NUMBER	DESCRIPTION	QTY
1	200-41-00-000	HD FRAME ASSY-2005	1
1.1	204-10-01-000	FOOT ASSY	2
1.1.1	204-10-01-084	FRAME ANGLE PC	1
1.1.2	204-10-01-085	FOOT	1
1.2	204-10-05-000	FRAME SIDE ASSY	2
1.2.1	204-10-05-120	TOP TUBE-2 1/2" PB BRG	1
1.2.2	204-10-00-081	ANGLE TUBE	2
1.2.3	204-10-00-083	VERTICAL SUPPORT TUBE	1
1.2.4	204-10-05-119	BRG STOP BLOCK	2
1.3	200-39-11-000	SIDE DRIVE FRAME ASSY	1
1.4	200-39-10-000	FLANGE BEARING HOLDER ASSY	1
1.4.1	200-39-10-287	FLANGE BRG MOUNT PLATE	1
1.4.2	200-39-02-234	BRAKE BASE PLATE	1
1.5	200-01-01-000	TONGUE PLATE ASSY	2
1.5.1	200-01-01-004	TONGUE PLATE	1
1.5.2	200-01-01-005	TOGUE PLATE SLEEVE	1
1.5.3	200-01-01-268	REINFORCING PLATE	1
1.6	200-37-02-000	CYLINDER LUG ASSY	2
1.6.1	200-37-02-248	LUG BASE PLATE	1
1.6.2	200-37-02-249	CYLINDER LUG	1
1.7	204-10-00-077	FRAME FRONT	1
1.8	204-10-00-075	LH FRAME SIDE	1
1.9	204-10-00-076	RH FRAME SIDE	1
1.10	204-10-00-078	FRAME CROSS BEAM	2
1.11	204-10-00-080	CENTER BEAM	1
1.12	204-10-00-079	AXLE TUBE	1
1.13	200-24-00-194	CENTER SPACER TUBE	1
1.14	204-01-00-005	REAR HITCH PLATE	1
1.15	200-24-00-215	FRAME GUSSET	7
1.16	204-10-00-087	TOOL BOX BRKT-UPPER RH	1
1.17	204-10-00-086	TOOL BOX BRKT-UPPER LH	1
1.18	204-10-00-089	TOOL BOX BRKT-LOWER RH	1
1.19	204-10-00-088	TOOL BOX BRKT-LOWER LH	1
1.20	200-41-00-283	VERTICAL CORNER GUSSET	4
1.21	200-41-00-284	FILLER CAP	3
1.22	200-24-00-243	TONGUE PLATE REINF. PC	2
1.23	R07785	1/2 HEX NUT	4
1.24	204-10-00-126	IDLER MOUNT PLATE	1
2	R09582	GREASE SYMBOL DECAL	4
3	R09071	SERIAL NUMBER PLATE	1
4	R08152	6 x 1/4 PAN HD SOCKET SCREW	2
5	R09654	"STAND CLEAR" DECAL	2

# HYDRAULIC TONGUE

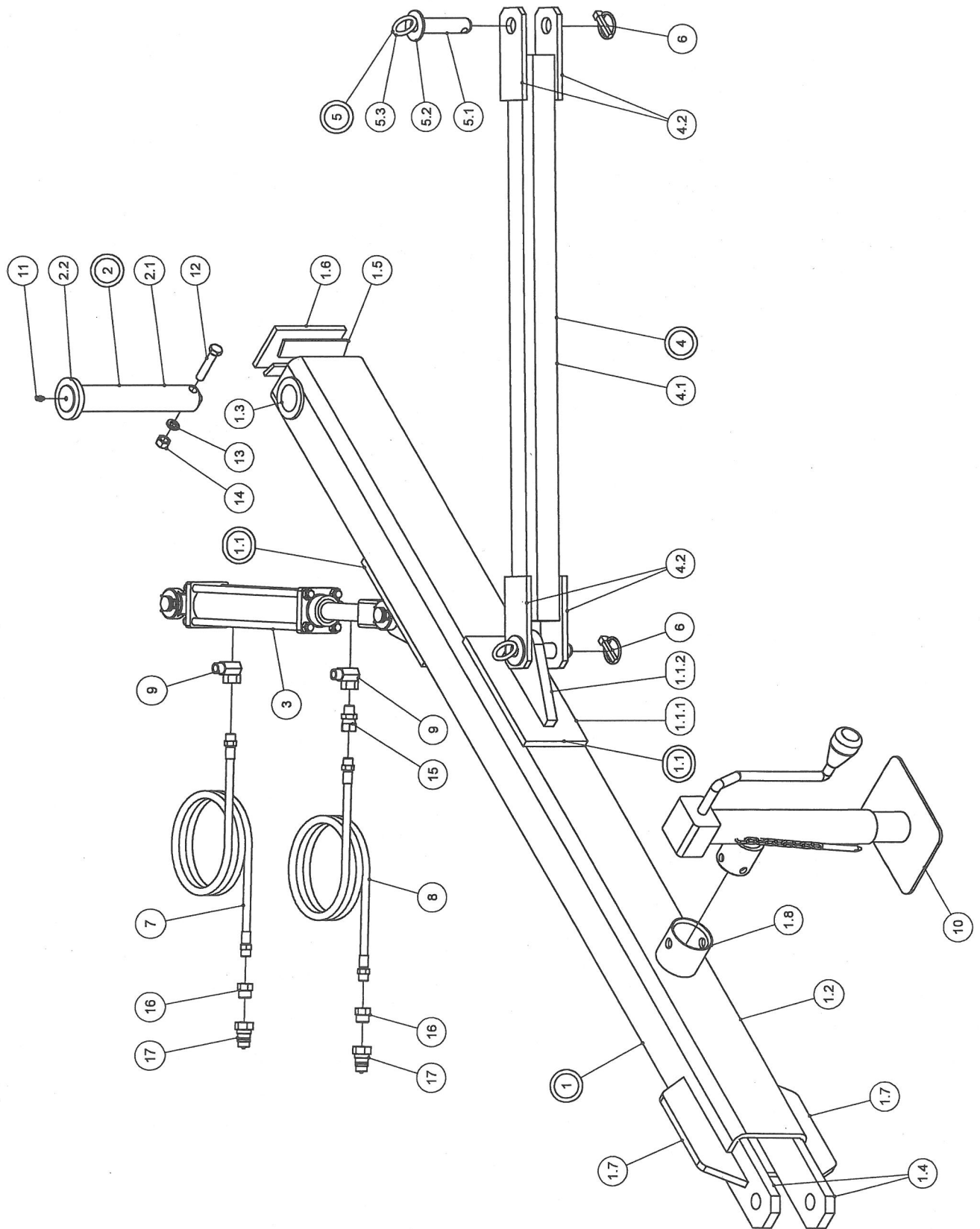



## HYDRAULIC TONGUE

PARTS LIST			
ITEM	PART NUMBER	DESCRIPTION	QTY
1	200-03-00-000	TONGUE TUBE ASSY	1
1.1	200-37-02-000	CYLINDER LUG ASSY	2
1.1.1	200-37-02-248	LUG BASE PLATE	1
1.1.2	200-37-02-249	CYLINDER LUG	1
1.2	200-03-00-017	TONGUE TUBE	1
1.3	200-03-00-018	PIVOT SLEEVE	1
1.4	200-03-00-019	HITCH TOP PC	2
1.5	200-03-00-271	SLEEVE SUPPORT	2
1.6	200-03-00-277	TONGUE END CAP	1
1.7	200-03-00-286	HITCH REINFORCING PLATE	2
1.8	364-35-00-245	TONGUE JACK BRKT	1
2	200-09-00-000	TONGUE PIN ASSY	1
2.1	200-09-00-042	TONGUE PIN	1
2.2	200-09-00-043	TONGUE PIN WASHER	1
3	R20725	2 x 8 HYDRAULIC CYLINDER	1
4	200-40-00-000	LONG STABILIZER BAR ASSY	1
4.1	200-40-00-269	LONG STABILIZER BAR	1
4.2	200-40-00-270	STABILIZER BAR BRKT	4
5	200-42-00-000	STABILIZER BAR PIN ASSY-LONG	2
5.1	200-42-00-282	STABILIZER BAR PIN-LONG	1
5.2	R07827	3/4" FLAT WASHER	1
5.3	R07925	1/4 x 1 1/2 PLATED RING	1
6	R08040	2 - 18 LYNCH PIN	2
7	242-34-00-000	HYDRAULIC HOSE ASSY	1
8	242-35-00-000	HYDRAULIC HOSE ASSY	1
9	R21366	3/8" x 90 DEG. NPT STREET ELBOW	2
10	R09751	7000LB SIDE WIND JACK	1
11	R08183	1/4" - 28 STRAIGHT GREASE FITTING	1
12	R07640	1/2 x 2 1/2 UNC HEX BOLT	1
13	R07805	1/2" LOCK WASHER	1
14	R07785	1/2-13 UNC HEX NUT	1
15	R21336	3/8 - 18 RESTRICTOR	1
16	R02043	BUSHING 1/2 x 3/8	2
17	R21342	1/2" MALE PIONEER TIP	2

# 7 HOSE REEL ASSY

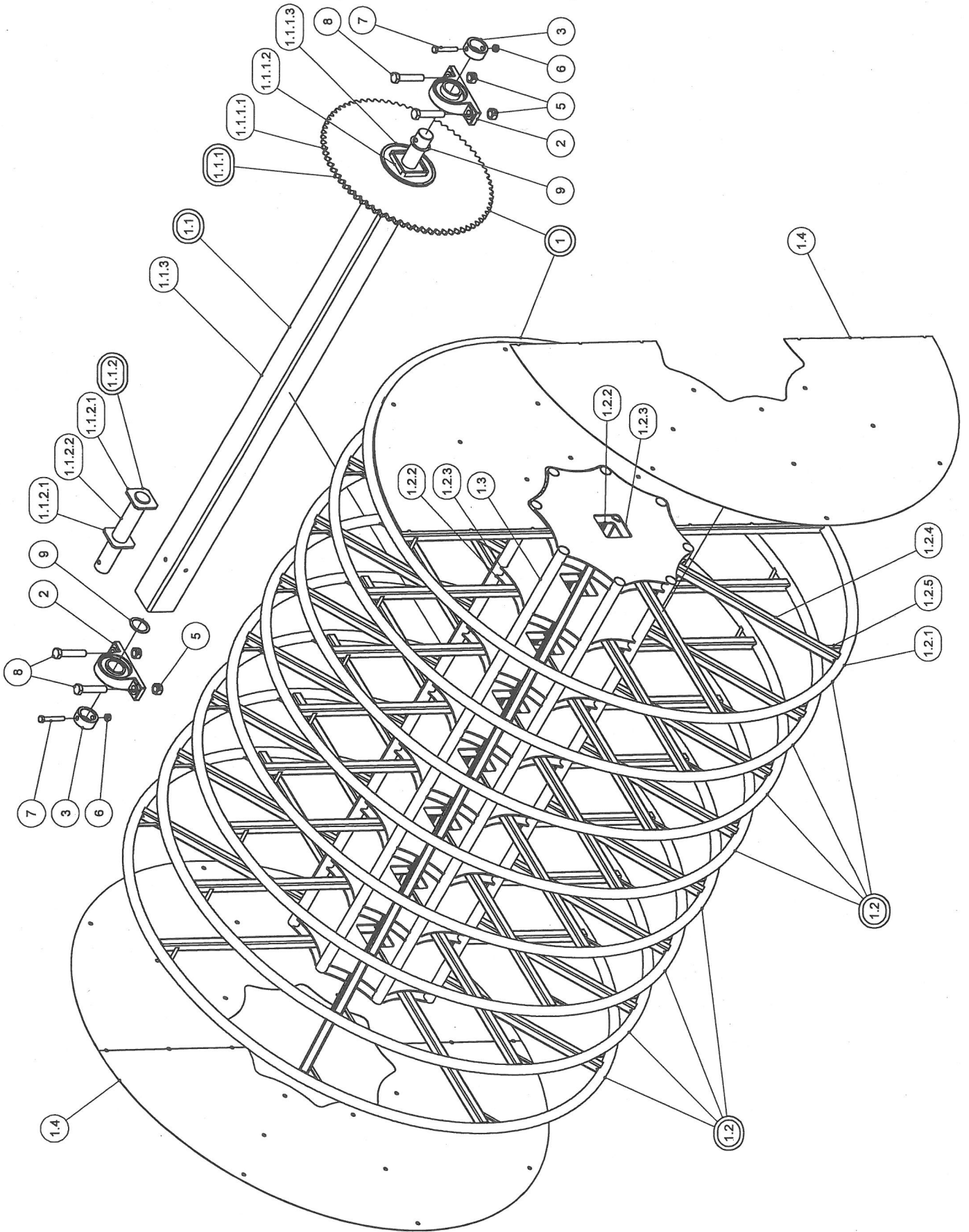

## 7 HOSE REEL ASSY

PARTS LIST			
ITEM	PART NUMBER	DESCRIPTION	QTY
1	200-68-00-000	7 SECTION REEL ASSY W/2 1/2" STUBS	1
1.1	204-13-01-000	CROSS TUBE ASSY-2 1/2" STUBS	1
1.1.1	204-06-02-000	HUB AND SPROCKET ASSY	1
1.1.1.1	R20924	100A-72 T SPROCKET	1
1.1.1.2	200-25-01-153	LARGE TUBE DISC	2
1.1.1.3	204-06-02-054	SPROCKET HUB	1
1.1.2	204-13-02-000	2 1/2" STUB SHAFT ASSY	2
1.1.2.1	204-13-02-118	STUB SHAFT PLATE	2
1.1.2.2	204-13-02-117	2 1/2" STUB SHAFT	1
1.1.3	204-13-01-121	CROSS TUBE	1
1.2	200-34-01-000	REEL ASSY	8
1.2.1	200-06-00-035	INNER REEL	1
1.2.2	200-34-01-197	REEL INNER PLATE	1
1.2.3	200-34-01-196	REEL OUTER PLATE	1
1.2.4	200-34-01-198	INNER SPOKE	8
1.2.5	200-05-00-031	STRAP HOOK	8
1.3	204-06-00-053	CROSS SHAFT	8
1.4	200-34-00-200	OUTER REEL SHIELD	4
2	R20469	2 1/2" PILLOW BLOCK BEARING	2
3	204-00-00-122	SHAFT COLLAR	2
5	R07882	1-8 UNC 2-WAY LOCK NUT	4
6	R07887	5/8-11 UNC 2-WAY LOCK NUT	2
7	R07651	5/8 x 4 UNC HEX BOLT	2
8	R07666	1 x 5 UNC HEX BOLT	4
9	204-00-00-127	DRUM SHIM	2

# SIDE DRIVE KIT

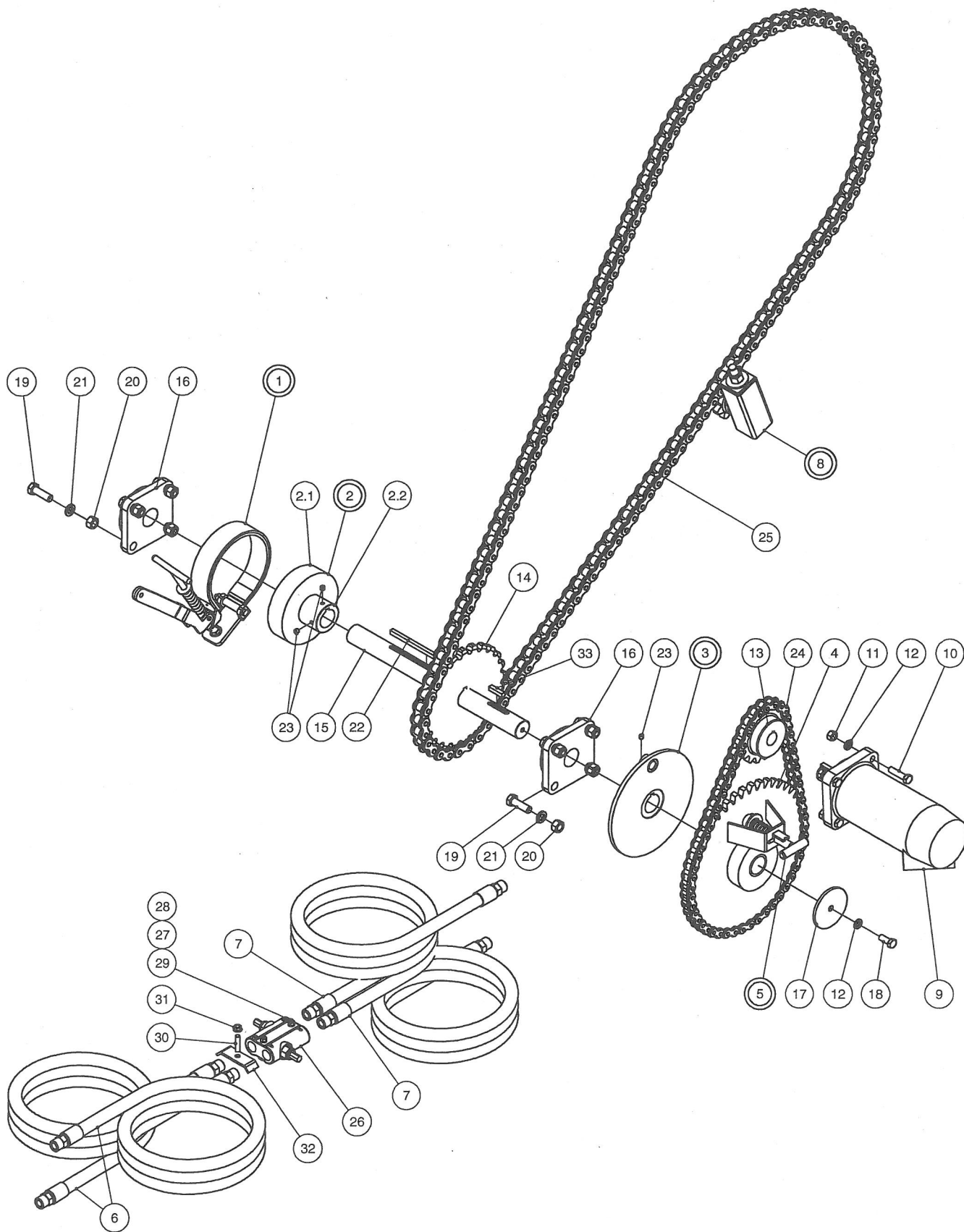

## SIDE DRIVE KIT

PARTS LIST			
ITEM	PART NUMBER	DESCRIPTION	QTY
1	200-12-00-000	BRAKE KIT	1
2	200-32-00-000	BRAKE DISC AND HUB ASSY	1
2.1	200-32-00-178	BRAKE DISC	1
2.2	200-32-00-179	BRAKE DISC HUB	1
3	200-30-00-000	DRIVE PLATE ASSY	1
4	200-31-00-000	DRIVE SPROCKET ASSY	1
5	200-22-06-000	LOCK PIN ASSY	1
6	204-01-08-000	3/4" HYD HOSE ASSY	2
7	200-39-06-000	3/4" HYD HOSE ASSY	2
8	200-11-00-000	CHAIN TIGHTENER KIT	1
9	R22267	6000 SERIES HYD MOTOR	1
10	R07639	1/2 x 2 UNC HEX BOLT	4
11	R07785	1/2-13 UNC HEX NUT	4
12	R07805	1/2" LOCK WASHER	5
13	R20655	80 B16 SPROCKET	1
14	R20928	100 B24 SPROCKET W/1 3/4" BORE	1
15	200-39-00-245	SPROCKET SHAFT	1
16	R20188	1 3/4" FLANGE BRG	2
17	200-00-00-195	CLUTCH WASHER	1
18	R07674	1/2 x 1 1/4 UNC HEX BOLT	1
19	R07647	5/8 x 2 UNC HEX BOLT	8
20	R07786	5/8-11 UNC HEX NUT	8
21	R07806	5/8" LOCK WASHER	8
22	200-00-00-217	3/8" KEY-225 LONG	1
23	R07909	3/8 x 3/8 SET SCREW	6
24	200-00-00-190	#80 ROLLER DRIVE CHAIN	1
25	200-00-00-191	#100 MAIN DRIVE CHAIN	1
26	R21249	DUAL RELIEF VALVE - REEL	1
27	R07782	5/16-18 UNC HEX NUT	2
28	R07802	5/16" LOCK WASHER	2
29	R07684	5/16 x 2 1/4 UNC HEX BOLT	2
30	R08302	3/8-16 UNC x 1 5/8" WELD STUD	5
31	R07794	3/8-16 UNC FLANGE NUT	5
32	351-00-00-009	HYD. HOSE FASTENER	5
33	200-00-00-218	3/8" KEY - 40 LONG	1

# SIDE FRAME, MOTOR MOUNT & GUARD

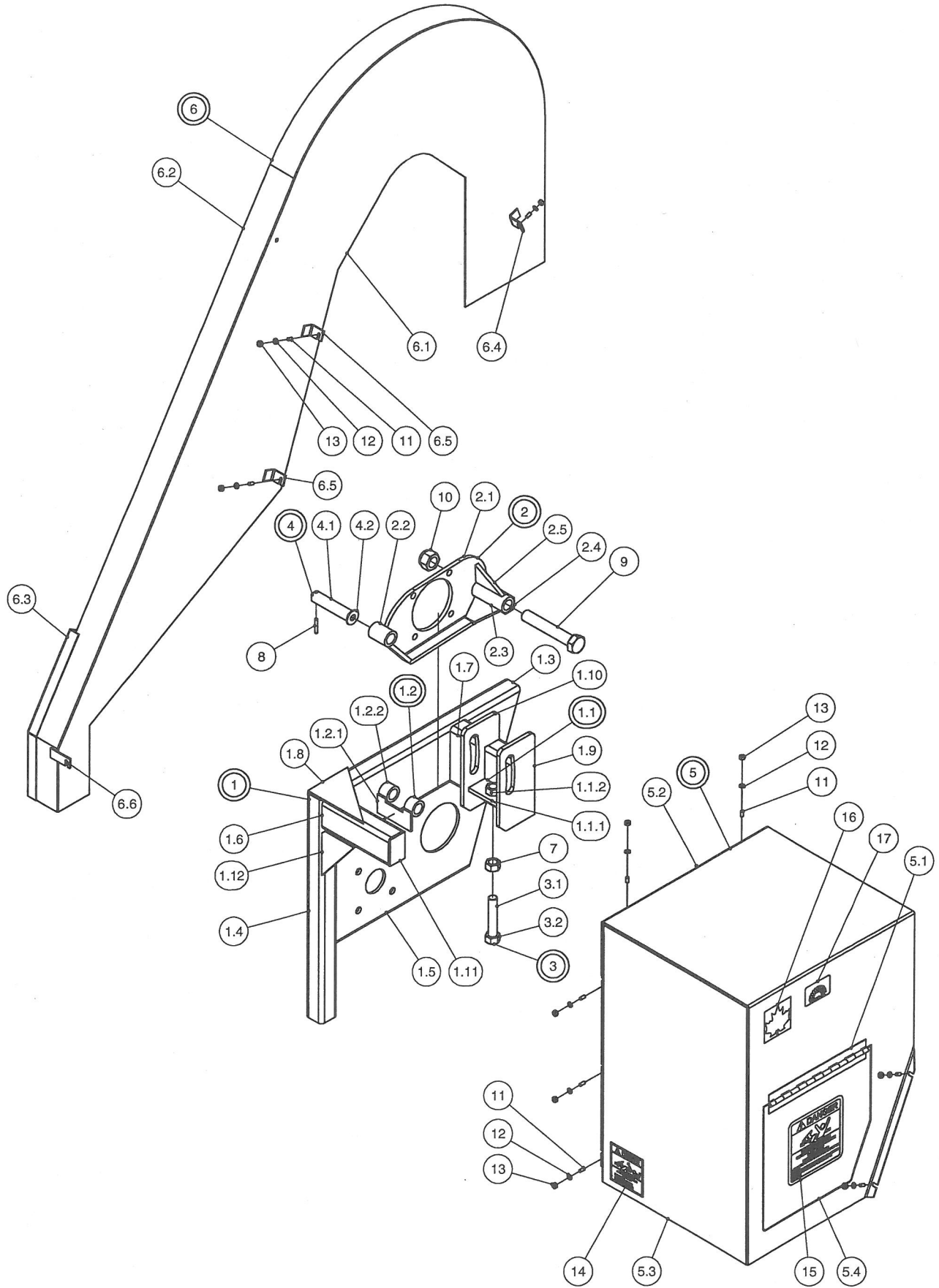



## SIDE FRAME, MOTOR MOUNT & GUARD

PARTS LIST			
ITEM	PART NUMBER	DESCRIPTION	QTY
1	200-39-11-000	SIDE DRIVE FRAME ASSY	1
1.1	200-22-12-000	TIGHTENER BRKT ASSY	1
1.1.1	200-22-12-219	TIGHTENER BRKT	1
1.1.2	R07787	3/4-10 UNC HEX NUT	1
1.2	200-22-02-000	BUSHING HOLDER ASSY	1
1.2.1	200-22-02-102	BUSHING HOLDER PLATE	1
1.2.2	200-22-02-101	HOLDER BUSHING	2
1.3	200-39-07-273	HORIZONTAL TUBE	1
1.4	200-39-01-222	VERTICAL POST	1
1.5	200-39-11-290	FLANGE BEARING PLATE	1
1.6	200-39-01-227	FRONT STUB TUBE	1
1.7	200-39-01-225	STUB TUBE	1
1.8	200-39-01-229	TOP GUSSET	1
1.9	200-39-01-226	CAP BRKT	1
1.10	200-22-00-209	TIGHTENER BRKT	1
1.11	200-39-01-228	END CAP	1
1.12	200-39-01-230	FRONT GUSSET	1
2	204-01-10-000	HYD MOTOR MOUNT ASSY-6000 SERIES	1
2.1	204-00-00-071	HYD MOTOR MOUNT-6000 SERIES MOTOR	1
2.2	200-22-03-104	MOUNT PLATE SLEEVE	1
2.3	200-22-11-211	MOTOR MOUNT LONG SLEEVE	1
2.4	200-22-11-238	ANGLE SEAT	1
2.5	200-22-11-212	SLEEVE GUSSET	1
3	200-22-08-000	TIGHTENER ROD ASSY	1
3.1	200-22-08-129	TIGHTENER ROD	1
3.2	R07787	3/4-10 UNC HEX NUT	1
4	200-22-09-000	HINGE PIN ASSY	1
4.1	200-22-09-130	HINGE PIN	1
4.2	R07825	1/2 FLAT WASHER	1
5	204-14-00-000	SIDE GUARD-6000 SERIES MOTOR	1
5.1	200-10-00-049	HINGE	1
5.2	204-14-00-124	SIDE GUARD	1
5.3	204-14-00-123	SIDE GUARD END PC	1
5.4	200-39-05-256	SIDE GUARD DOOR	1
6	200-39-08-000	LARGE OUTER GUARD ASSY-2002	1
6.1	200-39-08-274	LARGE GUARD OUTER PC	1
6.2	200-39-08-275	LARGE GUARD BAND	1
6.3	200-39-08-276	GUARD SIDE PC	1
6.4	200-39-09-281	RH CLIP	1
6.5	200-39-03-250	LH CLIP	2
6.6	200-39-03-251	STRAIGHT CLIP	1
7	R07787	3/4-10 UNC HEX NUT	1
8	R07962	1/4 x 1 1/2 ROLL PIN	1
9	R07667	1 x 6 UNC HEX BOLT	1
10	R08246	1 UNC NYLOCK NUT	1
11	R08301	1/4 x 20 UNC x 1/2" WELD STUD	10
12	R07801	1/4" LOCK WASHER	10
13	R07781	1/4-20 UNC HEX NUT	10
14	R21521	"ROTATING DRIVE LINE" DECAL	1
15	R09785	"DANGER ROTATING DRIVELINE" DECAL	1
16	R09509	"MADE IN CANADA" DECAL - LARGE	1
17	OFEMA	O.F.E.M.A. DECAL	1

# IDLER & MOUNT ASSY

**IDLER & MOUNT ASSY  
200-11-00-000**

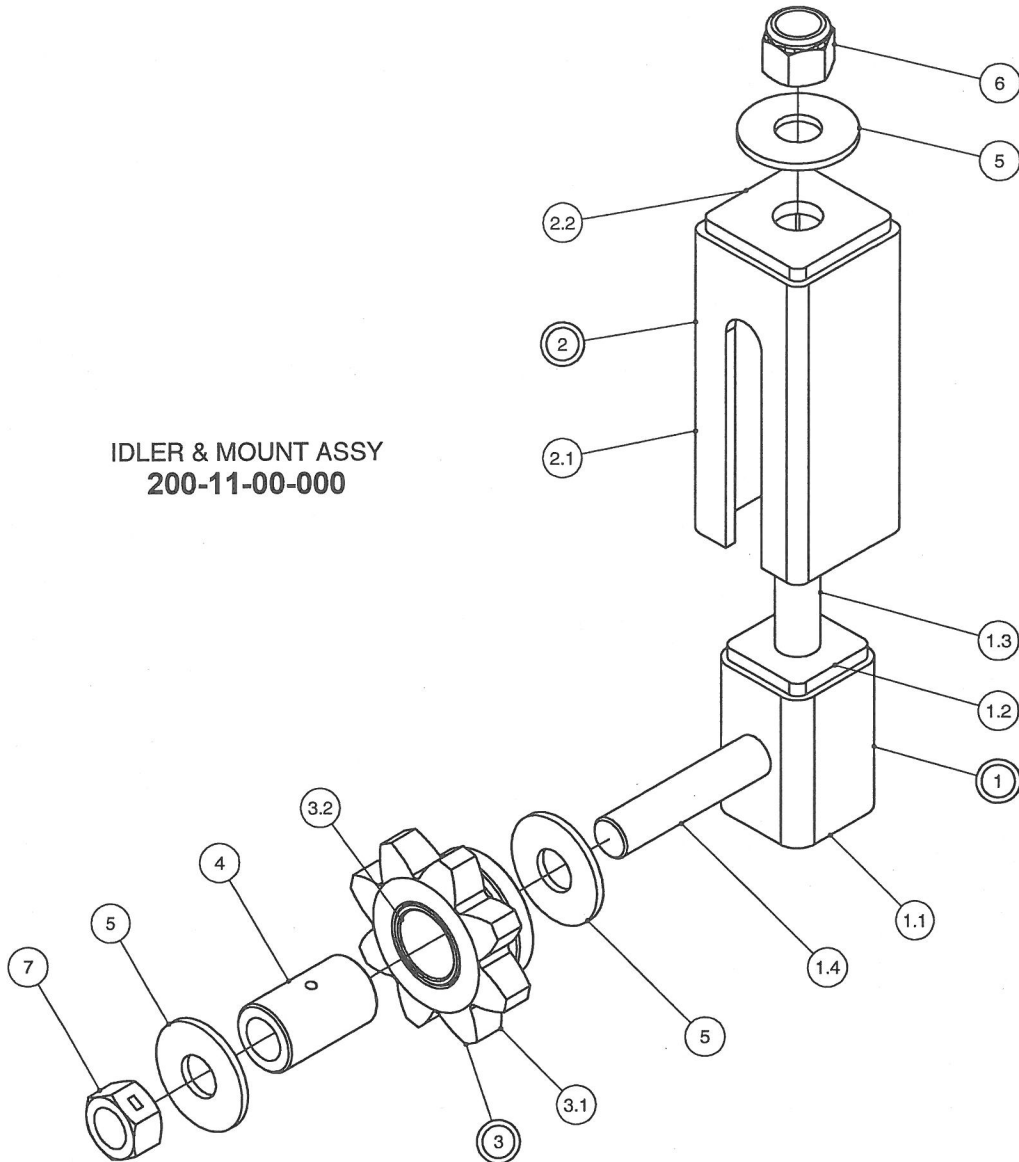

PARTS LIST			
ITEM	PART NUMBER	DESCRIPTION	QTY
1	200-11-01-000	TIGHTENER INNER TUBE ASSY	1
1.1	200-11-01-054	INSIDE TUBE	1
1.2	200-11-01-055	INNER TUBE CAP	1
1.3	200-11-01-058	TIGHTENER ROD	1
1.4	200-11-01-059	IDLER STUD	1
2	200-11-02-000	TIGHTENER OUTER TUBE ASSY	1
2.1	200-11-02-056	OUTER TUBE	1
2.2	200-11-02-057	OUTER TUBE CAP	1
3	200-11-03-000	IDLER SPROCKET ASSY	1
3.1	200-11-00-192	IDLER SPROCKET	1
3.2	R20255	1.5 OD X 1.25 ID X 1.5 LONG BRASS BUSHING	1
4	460-00-00-035	IDLER SLEEVE	1
5	R07827	3/4" FLAT WASHER	3
6	R07878	3/4 NYLOCK NUT	1
7	R07881	3/4-10 UNC 2-WAY LOCK NUT	1

## TOOL BOXES

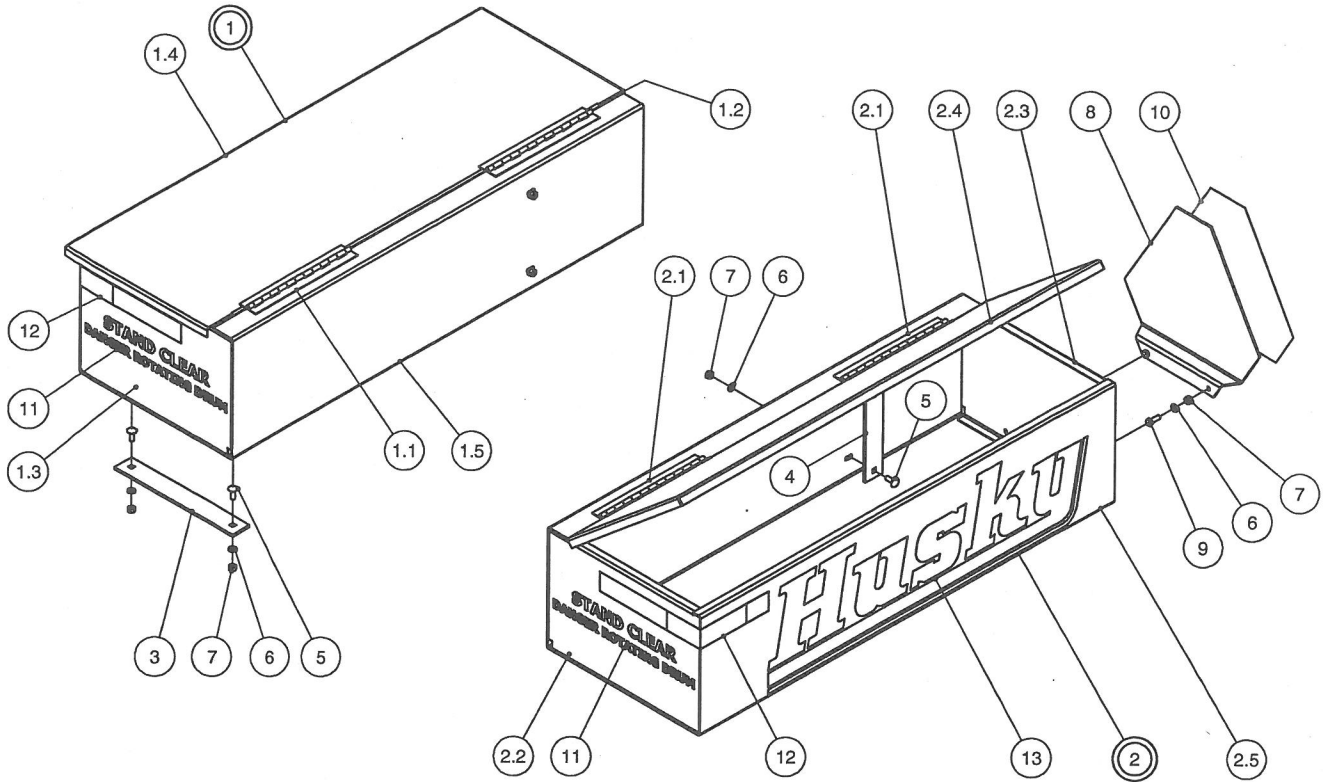

PARTS LIST			
ITEM	PART NUMBER	DESCRIPTION	QTY
1	200-10-00-000	RH TOOL BOX ASSY	1
1.1	200-10-00-049	HINGE	2
1.2	200-10-00-047	TOOL BOX LH SIDE	1
1.3	200-10-00-046	TOOL BOX LH SIDE	1
1.4	200-10-00-048	TOOL BOX LID	1
1.5	200-10-00-045	RH TOOL BOX BODY	1
2	200-33-00-000	LH TOOL BOX ASSY	1
2.1	200-10-00-049	HINGE	2
2.2	200-10-00-047	TOOL BOX LH SIDE	1
2.3	200-33-00-188	TOOL BOX RH SIDE	1
2.4	200-10-00-048	TOOL BOX LID	1
2.5	200-33-00-186	LH TOOL BOX BODY	1
3	200-00-00-158	TOOL BOX REINFORCING BAR	2
4	200-00-00-244	VERT. TOOL BOX REIN. BAR	2
5	R07721	3/8 x 1 UNC CARRIAGE BOLT	8
6	R07803	3/8" LOCK WASHER	10
7	R07783	3/8-16 UNC HEX NUT	10
8	200-00-00-132	S.M.V. SIGN HOLDER	1
9	R07619	3/8 x 1 UNC HEX BOLT	2
10	R09501	SLOW MOVING VEHICLE DECAL	1
11	R09654	"STAND CLEAR" DECAL	2
12	R10361	REFLECTOR TAPE - RED/SILVER	2
13	R10338	"HUSKY" DECAL - REEL	2

## BRAKE KIT

**BRAKE KIT  
200-12-00-000**

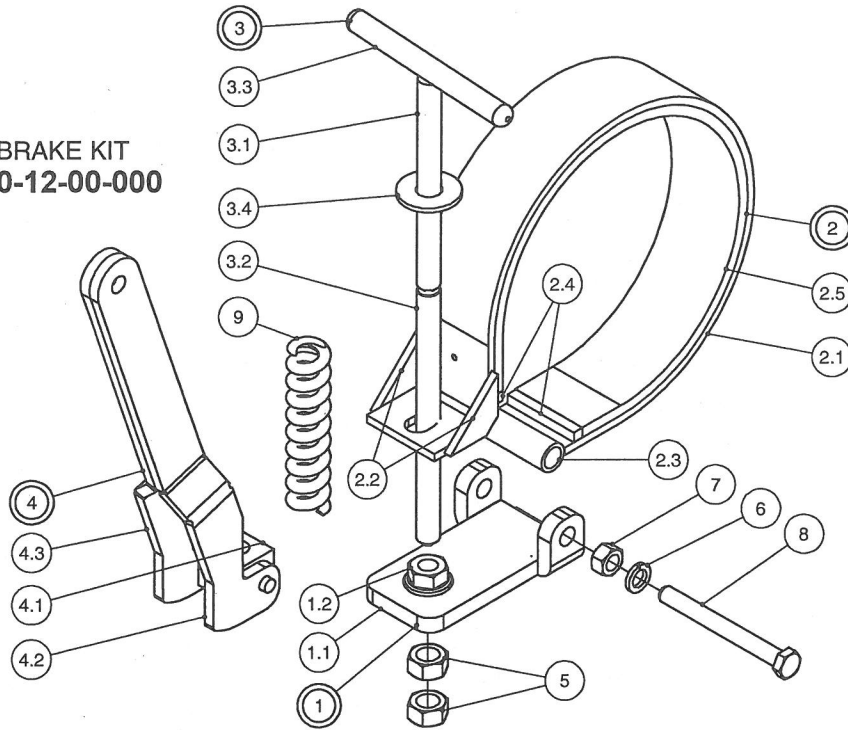

### PARTS LIST

ITEM	PART NUMBER	DESCRIPTION	QTY
1	200-12-02-000	BRAKE MOUNT PLATE ASSY	1
1.1	200-12-02-074	MOUNT PLATE	1
1.2	R07795	1/2" UNC FLANGE NUT	1
2	200-12-01-000	BRAKE BAND ASSY	1
2.1	200-12-01-069	BRAKE BAND	1
2.2	200-12-01-070	GUSSET	2
2.3	200-12-01-071	BAND SLEEVE	1
2.4	200-12-01-072	STOP	2
2.5	200-12-01-073	BRAKE LINING	1
3	200-12-03-000	BRAKE HANDLE ASSY	1
3.1	200-12-03-076	HANDLE EXTENSION	1
3.2	200-12-03-077	HANDLE READY THREAD	1
3.3	200-12-03-075	HANDLE TOP	1
3.4	R07825	1/2 FLAT WASHER	1
4	200-12-04-000	BRAKE HANDLE ASSY	1
4.1	200-12-04-201	HANDLE YOKE	1
4.2	200-12-04-202	RH HANDLE	1
4.3	200-12-04-203	LH HANDLE	1
5	R07785	1/2 HEX NUT	2
6	R07803	3/8 LOCK WASHER	1
7	R07783	3/8 HEX NUT	1
8	R07624	3/8 X 3 1/2" HEX BOLT	1
9	R08069	25.4 OD X 102 LONG SPRING	1

## DRIVE SPROCKET, PLATE & LOCK

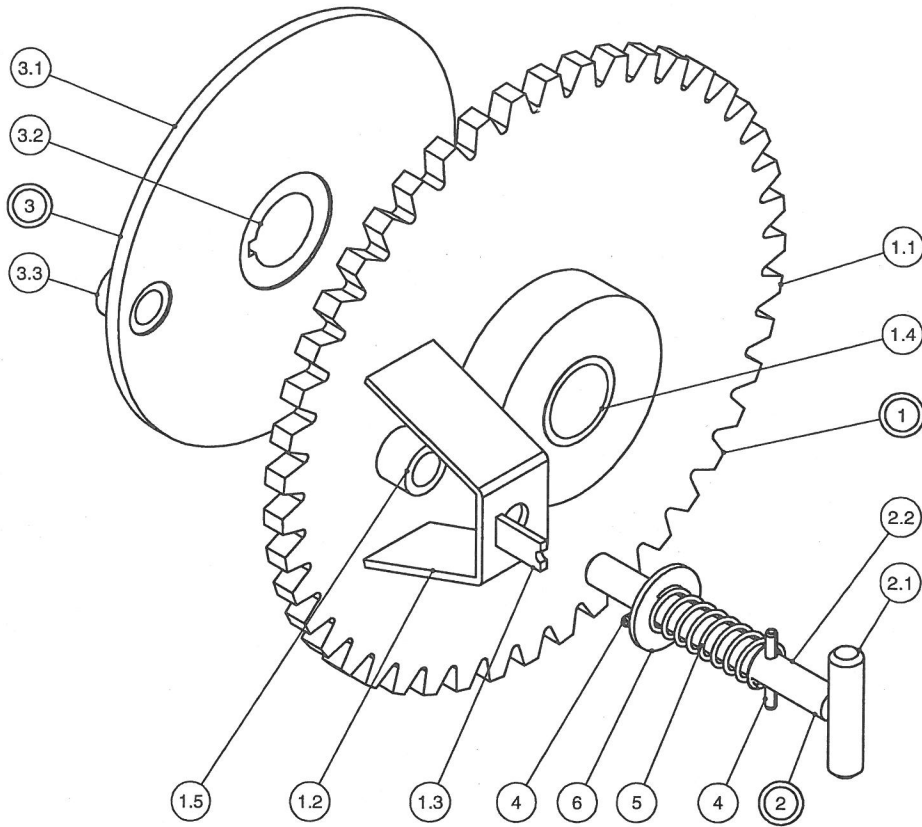

PARTS LIST			
ITEM	PART NUMBER	DESCRIPTION	QTY
1	200-31-00-000	DRIVE SPROCKET ASSY	1
1.1	200-31-00-157	DRIVE SPROCKET 100B-36	1
1.2	200-22-05-108	LOCK BRKT	1
1.3	200-22-05-109	PIN STOP	1
1.4	R21199	1 3/4 x 2 1/8 x 2" LONG BUSHING	1
1.5	308-57-00-165	HARDENED BUSHING	1
2	200-22-06-000	LOCK PIN ASSY	1
2.1	200-22-06-110	HANDLE	1
2.2	200-22-06-111	LOCK PIN	1
3	200-30-00-000	DRIVE PLATE ASSY	1
3.1	200-30-00-155	DRIVE PLATE	1
3.2	200-30-00-156	DRIVE PLATE HUB	1
3.3	308-57-00-165	HARDENED BUSHING	1
4	R07942	1/4 x 2" ROLL PIN	2
5	R08038	1 1/8 x 3 x .105 COMPRESSION SPRING	1
6	R07827	3/4" FLAT WASHER	1

# TANDEM AXLE KIT

TANDEM AXLE KIT  
200-02-00-000  
(OPTIONAL)

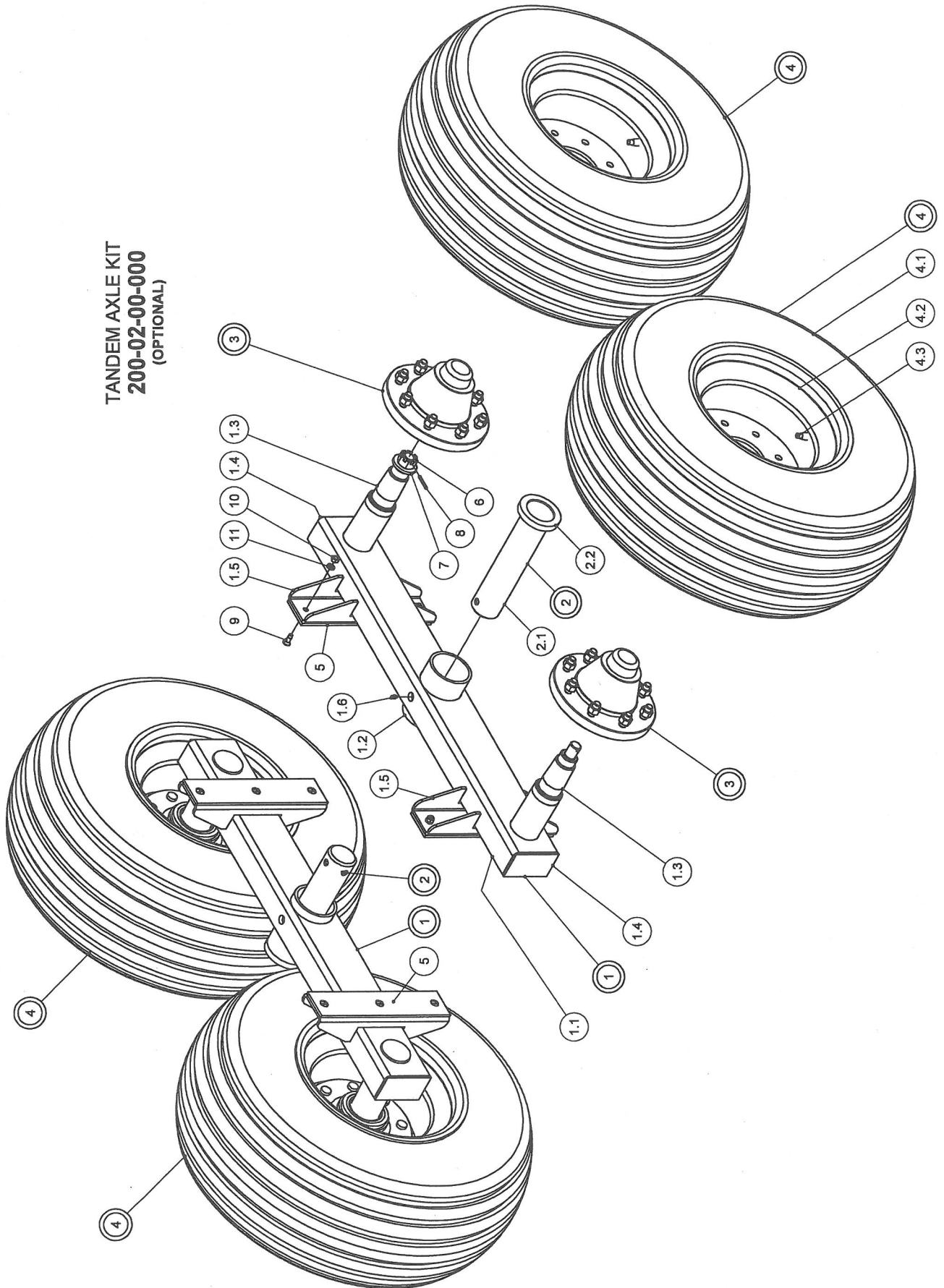



## TANDEM AXLE KIT

PARTS LIST			
ITEM	PART NUMBER	DESCRIPTION	QTY
1	200-02-01-000	WALKING BEAM ASSY	2
1.1	200-02-01-011	WALKING BEAM	1
1.2	200-02-01-012	WALKING BEAM SLEEVE	1
1.3	200-02-01-014	TANDEM AXLE SPINDLE	2
1.4	200-02-01-013	END CAP	2
1.5	200-02-01-255	WALKING BEAM GUIDE	2
1.6	R08183	1/4" - 28 STRAIGHT GREASE FITTING	1
2	200-67-00-000	STUB SHAFT ASSY-2003	2
2.1	200-67-00-289	STUB SHAFT	1
2.2	200-02-02-016	STUB SHAFT STOP	1
3	300-27-00-000	8 - BOLT HUB COMPLETE	4
4	365-61-00-000	12.5L X 15 - 10 PLY TIRE ASSY	4
4.1	R20035	12.5L X 15 10PLY TIRE	1
4.2	R20049	15 X 10 X 8 BOLT WHEEL	1
4.3	R20020	VALVE STEM	1
5	200-00-00-189	UHMW GUIDE PLATE	4
6	R20117	SPINDLE NUT	4
7	R20118	SPINDLE WASHER	4
8	R07943	3/16 x 1 1/2 ROLL PIN	4
9	R08156	3/8 x 1" FLAT SLOT HEAD MACHINE SCREW	12
10	R07783	3/8-16 UNC HEX NUT	12
11	R07803	3/8" LOCK WASHER	12

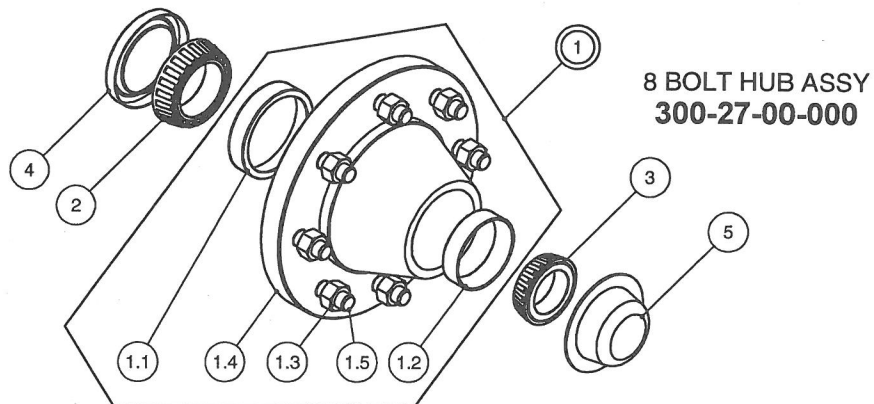

PARTS LIST			
ITEM	PART NUMBER	DESCRIPTION	QTY
1	300-27-00-574	8 - BOLT HUB COMPLETE	1
1.1	R20112	INNER CUP	1
1.2	R20113	OUTER CUP	1
1.3	R20111	5/8 x 18 UNF WHEEL NUT	8
1.4	R20126	8 BOLT HUB LESS CUPS	1
1.5	R20124	5/8 - 18 UNF x 2 3/8 WHEEL BOLT	8
2	R20114	INNER CONE	1
3	R20115	OUTER CONE	1
4	R20116	HUB SEAL	1
5	R20119	DUST CAP	1

# SINGLE AXLE KIT

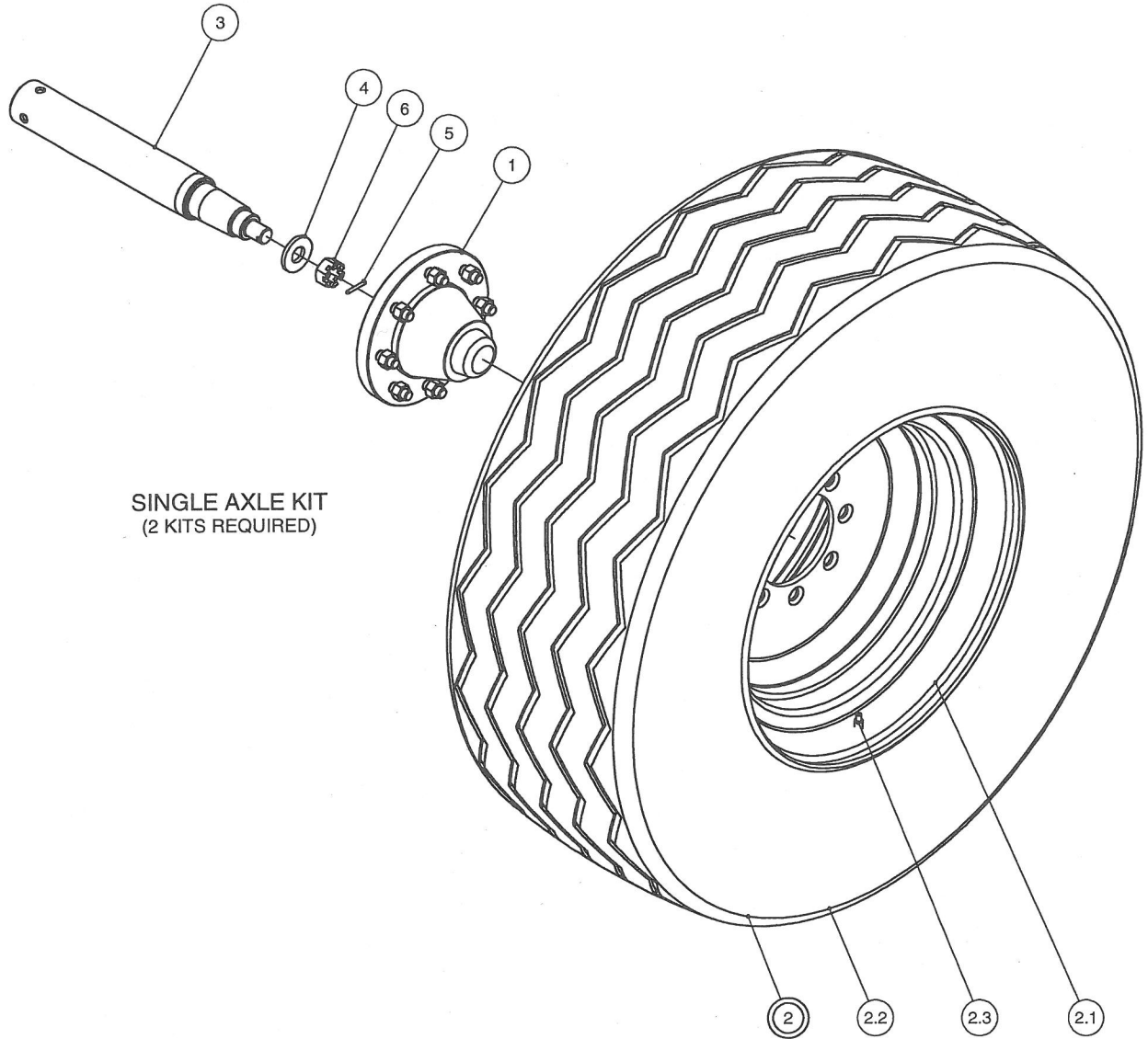

PARTS LIST			
ITEM	PART NUMBER	DESCRIPTION	QTY
1	300-27-00-000	8 - BOLT HUB COMPLETE	1
2	340-55-00-000	18 x 22.5 TRUCK TIRE, TUBE & WHEEL	1
2.1	R20058	8 BOLT WHEEL 13.5 x 22.5	1
2.2	R20011	18 x 22.5 USED TRUCK TIRE	1
2.3	R20050	VALVE STEM FOR TRUCK TIRE	1
3	200-00-00-288	SINGLE AXLE SPINDLE	1
4	R20118	SPINDLE WASHER	1
5	R07943	3/16 x 1 1/2 ROLL PIN	1
6	R20117	SPINDLE NUT	1