

*Office copy
Feb-15/91
20 made
Nov 20/91
10 made*

DATE PURCHASED _____ MACHINE SERIAL NO. _____
SIZE OF PUMP _____ OPTIONS _____

PLEASE NOTE:

The key number system in this parts book is arranged as follows:

- 0 --Key number with one circle denotes main assemblies
- Key numbers not circled are individual parts

Please order parts by number

K 31

HUSKY LIQUID MANURE PUMP

OPERATING INSTRUCTIONS:

1. Do not leave pump in manure pit - remove pump from pit - wash off and cover with old oil or diesel fuel.
2. Always idle tractor down before changing from pumping to agitating.
3. Do not overrev. tractor while pumping as discharge spout will lift into the air. If pumping fast tie down spout.
4. The (Urethane) marine bearing at the bottom of the pump is lubricated with manure or water. If the level of the liquid is below the bearing and you are running for long periods put a water hose in the top of standpipe.
5. EXTREME DANGER: - Never enter a dirty Manure Spreader or Storage Tank - one breath of Hydrogen Sulfide Gas is enough to kill.

KEY	PART NUMBER	DESCRIPTION	QTY
1	250-80-00-000	LOWER VALVE & TEE ASSY COMPLETE	1
2	250-79-00-000	WELDED VALVE ASSY W/O INSIDES	1
3	250-09-08-000	LOWER CONE ASSY	1
4	250-67-00-000	STANDPIPE ASSY - 8FT PUMP	1
	252-68-00-000	STANDPIPE ASSY -10FT PUMP	1
	254-69-00-000	STANDPIPE ASSY -12FT PUMP	1
5	250-67-00-152	STANDPIPE - 8FT PUMP	1
	252-68-00-153	STANDPIPE -10FT PUMP	1
	254-69-00-154	STANDPIPE -12FT PUMP	1
6	250-15-00-000	UPPER VALVE & EXTENSION PIPE ASSY	1
7	250-14-00-000	UPPER VALVE ASSY COMPLETE	1
8	250-15-17-000	UPPER EXTENSION PIPE ASSY	1
9	250-19-00-000	CONTROL ROD ATTACHMENT ASSY	1
10	250-22-00-000	CONTROL ROD ASSY	2
11	250-20-00-000	LOWER CONTROL ROD ASSY - 8FT PUMP	1
	252-42-00-000	LOWER CONTROL ROD ASSY -10FT PUMP	1
	254-43-00-000	LOWER CONTROL ROD ASSY -12FT PUMP	1
12	250-67-33-000	CONTROL PLATE ASSY	1
13	250-09-08-031	CONE MOUNT	2
14	250-15-17-125	STOP RING	1

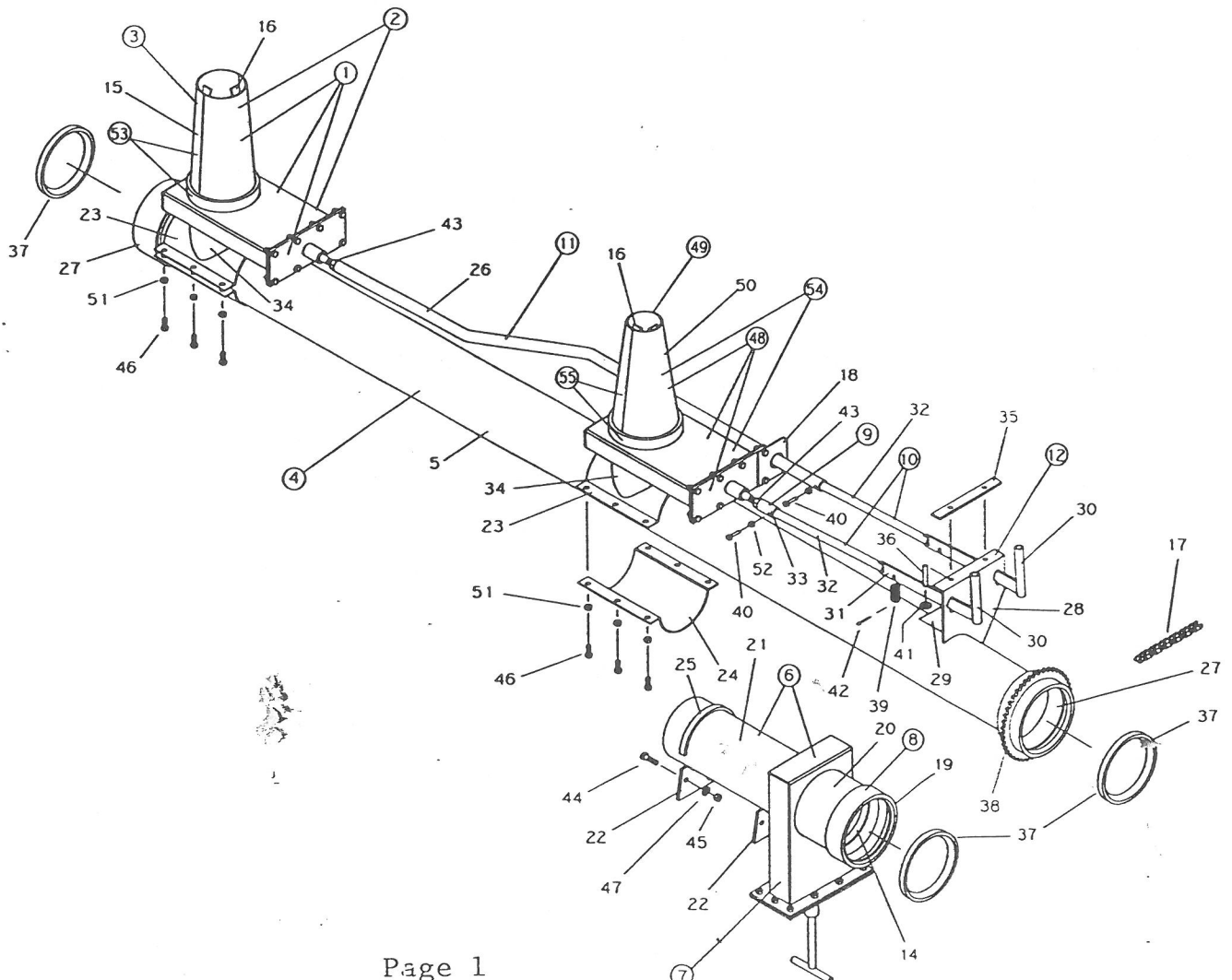

STANDPIPE

<u>KEY</u>	<u>PART NUMBER</u>	<u>DESCRIPTION</u>	<u>QTY</u>
15	250-09-08-036	TEE CONE	2
16	250-09-08-037	CONE RIBS	8
17	250-00-00-104	#50 ROLLER CHAIN -69 PITCHES & C/L	1
18	250-00-00-160	CONTROL ROD SUPPORT	1

19	250-12-10-042	COUPLING BASE TUBE	1
20	250-15-17-061	VALVE EXTENSION PIPE	1
21	250-15-00-059	FIXED UPPER STANDPIPE	1
22	250-15-00-060	MOUNT BRKT	2

23	250-66-00-150	CONE CLAMP ON BRKT	2
24	250-00-00-151	CLAMP ON BRKT	2
25	250-15-00-170	STOP RING	1
26	250-20-00-075	LOWER CONTROL ROD - 8FT PUMP	1

	252-42-00-110	LOWER CONTROL ROD -10FT PUMP	1
	254-43-00-112	LOWER CONTROL ROD -12FT PUMP	1
27	250-67-00-168	GASKET SLEEVE	2
28	250-67-33-178	CONTROL PLATE	1

29	250-12-00-044	CONTROL PLATE GUSSET	1
30	250-21-00-072	LEVER HANDLE	2
31	250-21-00-076	LEVER PLATE	2
32	250-22-00-046	UPPER CONTROL ROD	2

33	250-19-00-045	UPPER CONTROL ROD ATTACHMENT	1
34	250-09-07-035	TEE SIDE	2
35	250-00-00-175	SPRING PLATE	1
36	250-67-33-176	CONTROL PLATE PIN	2

37	R02366	6" RUBBER GASKET	3
38	R20612	50 A 44 SPROCKET	1
39	R08024	CONTROL PLATE SPRING	2
40	R07603	1/4 X 1 1/2 HEX BOLT	2

41	R07832	3/8 FLAT WASHER	2
42	R08021	1/8 X 1 COTTER PIN	2
43	R07786	5/8" HEX NUT	4
44	R07628	7/16 X 1 HEX HD BOLT	6

45	R07784	7/16 HEX NUTS	18
46	R07671	7/16 X 1 1/4 HEX HD BOLT	12
47	R07804	7/16 LOCK WASHER	6
48	250-86-00-000	UPPER VALVE & TEE ASSY COMPLETE	1

49	250-86-43-000	UPPER CONE ASSY	1
50	250-86-43-214	UPPER CONE	2
51	R07879	7/16 FLANGE NUT	12
52	R07781	1/4" HEX NUT	2

53	250-79-53-000	LOWER CONE & MOUNT ASSY	1
54	250-90-00-000	UPPER WELDED VALVE ASSY W/O INSIDES	1
55	250-90-54-000	UPPER CONE & MOUNT ASSY	1

AGITATOR VALVE
250-79-00-000

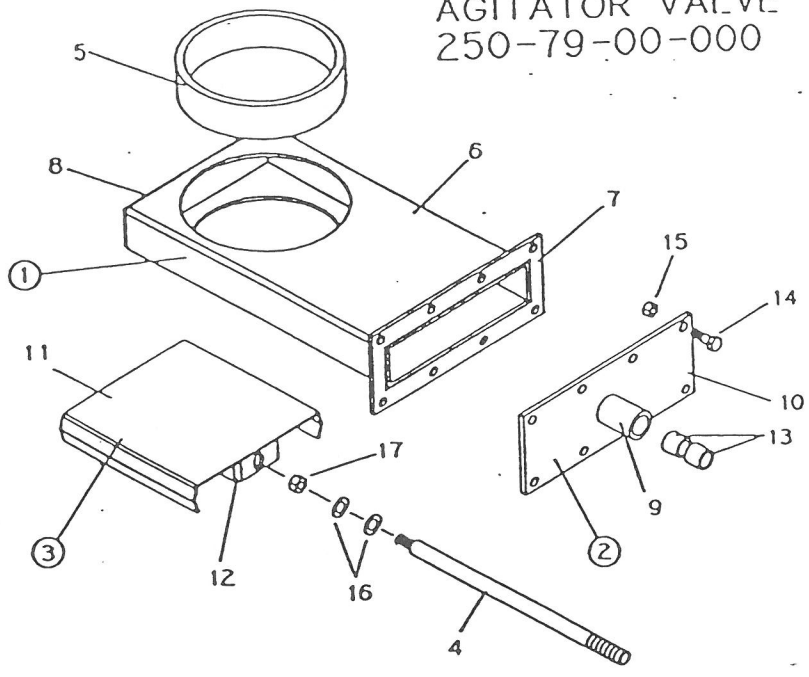

UPPER VALVE ASSY
250-14-00-000

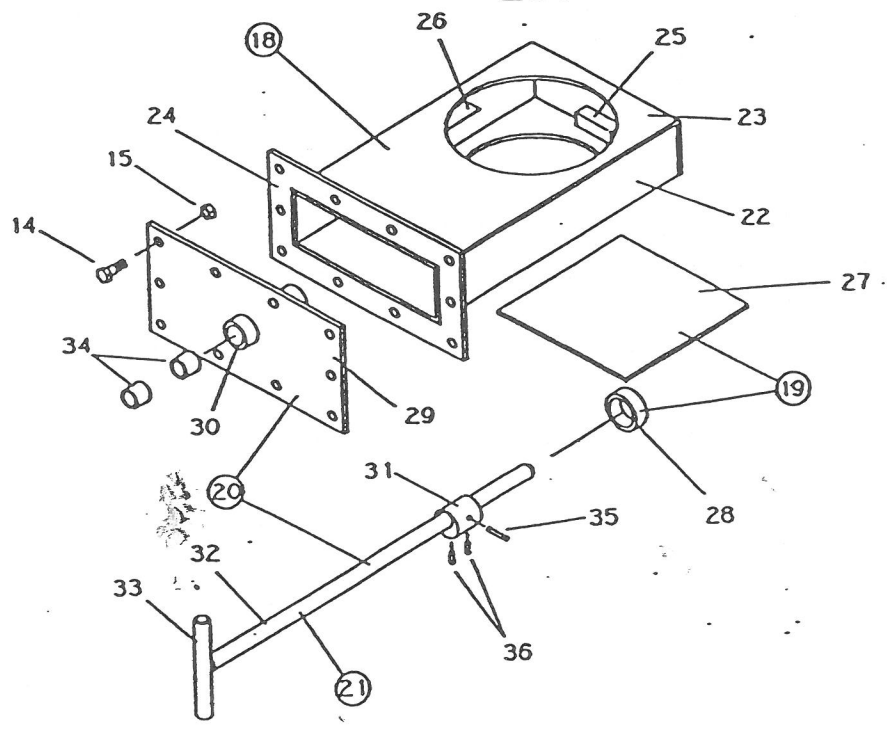

VALVES

<u>KEY</u>	<u>PART NUMBER</u>	<u>DESCRIPTION</u>	<u>QTY</u>
1	250-79-33-000	AGITATOR VALVE HOUSING ASSY	1
2	250-79-36-000	OUTER FLANGE ASSY	1
3	275-17-00-000	VALVE GATE	1
4	250-00-00-023	AGITATOR VALVE SHAFT	1

5	250-09-08-031	CONE MOUNT	1
6	250-79-35-189	VALVE HOUSING	1
7	275-01-02-012	VALVE FLANGE	1
8	275-01-02-062	VALVE END CAP	1

9	250-08-06-030	VALVE BUSHING	1
10	250-79-36-188	AGITATOR VALVE OUTER FLANGE	1
11	275-17-00-080	VALVE GATE	1
12	275-17-00-081	VALVE GATE BRKT	1

13	R21167	7/8OD X 5/8ID 3/4 LONG BRASS BUSHING	2
14	R07619	3/8 X 1 HEX HD BOLT	8
15	R07794	3/8 FLANGE NUT	8
16	R08231	3/8 SS SAE FLAT WASHER	2

17	R08228	7/16 SS NYLON INSERT NUT	1
18	250-14-12-000	UPPER VALVE HOUSING ASSY	1
19	250-14-13-000	UPPER VALVE GATE ASSY	1
20	250-14-14-000	VALVE COVER & SHAFT ASSY	1

21	250-14-15-000	HANDLE ASSY	1
22	250-14-12-047	UPPER VALVE BOTTOM PLATE	1
23	250-14-12-048	UPPER VALVE COVER PLATE	1
24	250-14-12-049	UPPER VALVE FLANGE	1

25	250-14-12-050	HOLD DOWN BAR	1
26	250-14-12-051	VALVE GUIDE	2
27	250-14-13-052	UPPER VALVE GATE	1
28	250-14-13-053	CAM HOLDER	1

29	250-14-14-054	UPPER VALVE COVER PLATE	1
30	250-14-14-055	VALVE BRG SLEEVE	1
31	250-14-14-056	CAM	1
32	250-14-15-057	UPPER VALVE SHAFT	1

33	250-14-15-058	TEE HANDLE	1
34	R21167	7/8OD X 5/8ID X 3/4 LONG BRASS BUSHING	2
35	R08241	3/16 X 1 S.S. ROLL PIN	1
36	R08237	3/16 X 1/2 S.S. ROLL PIN	2

KEY	PART NUMBER	DESCRIPTION	QTY
1	250-76-00-000	MARINE BRG & HOLDER COMPLETE	1
2	250-76-34-000	MARINE BRG HOLDER ASSY	1
3	250-05-00-000	SHAFT TUBE ASSY - 8 FT MODEL	1
	252-38-00-000	SHAFT TUBE ASSY - 10 FT MODEL	1
	254-39-00-000	SHAFT TUBE ASSY - 12 FT MODEL	1
4	250-89-00-000	CRANK BRACKET ASSY	1
5	250-16-00-000	GEARBOX BRKT ASSY	1
6	250-16-18-000	UPPER CRANK BRKT ASSY	1
7	250-18-00-000	LOCK PIN ASSY W/CHAIN	1
8	250-17-00-000	CRANK ASSY	1
9	250-59-00-000	SET SCREW ASSY	1
10	250-76-34-180	URETHENE BRG SLEEVE	1
11	250-76-34-181	BRG SLEEVE HOLDER	2
12	250-16-18-066	SLEEVE	2
13	250-05-00-014	SHAFT TUBE - 8 FT MODEL	1
	252-38-00-109	SHAFT TUBE - 10 FT MODEL	1

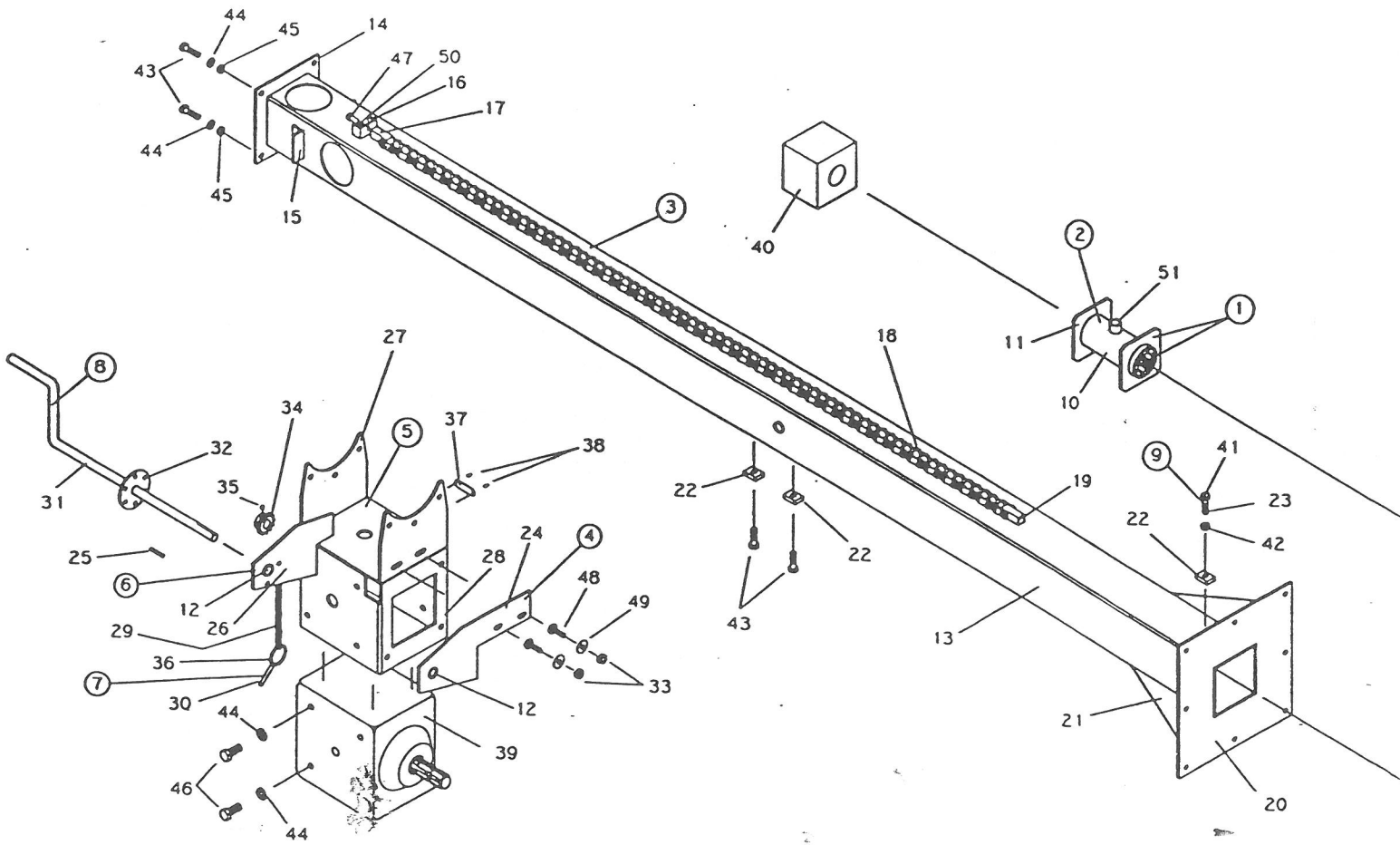

SHAFT TUBE

KEY	PART NUMBER	DESCRIPTION	QTY
	254-39-00-111	SHAFT TUBE - 12 FT MODEL	1
14	250-05-00-016	SHAFT TUBE FLANGE	1
15	250-05-00-017	SPOOL HOLDER STOP	2
16	242-11-00-061	TIGHTENER BELT	1
17	242-00-00-066	CHAIN TIGHTENER	1
18	242-00-00-065	ROLLER CHAIN - 8FT.	1
	244-00-00-169	ROLLER CHAIN -10FT.	1
	246-00-00-177	ROLLER CHAIN -12FT.	1
19	242-11-00-059	CHAIN HOLD DOWN BRKT	1
20	250-05-00-073	LOWER SHAFT TUBE FLANGE	1
21	250-05-00-077	SHAFT TUBE GUSSET	4
22	250-05-00-126	SS SET SCREW LUG	3
23	250-59-00-141	SS SET SCREW REDDI ROD	1
24	250-13-00-068	CRANK BRKT	1
25	250-00-00-124	3/16 KEY	1
26	250-16-18-065	UPPER CRANK BRKT	1
27	250-16-00-064	GEARBOX BRKT COVER PLATE	1
28	250-16-00-063	GEARBOX BRKT	1
29	250-18-00-067	LOCK PIN CHAIN	1
30	250-18-00-071	LOCK PIN	1
31	250-17-00-069	CRANK	1
32	250-17-00-070	CRANK LOCK PLATE	1
33	R07784	7/16 HEX NUT	2
34	R20613	50B12 SPROCKET - 3/4 BORE	1
35	R07903	1/4 X 3/8 SET SCREW	1
36	R07925	1/4 X 1 1/2 PLATED RING	1
37	R09716	SERIAL NUMBER PLATE	1
38	R08162	TYPE "U" DRIVE SCREW	2
39	R20670	MODEL 511 GEARBOX 1:1.5	1
40	R20233	1 7/8 SQUARE WOOD BRG	1
41	R08235	1/2-13 SS HEX NUT	1
42	R08046	1/2-13 JAM NUT	1
43	R07674	1/2 X 1 1/4 HEX HD BOLT	6
44	R07805	1/2" LOCK WASHER	12
45	R07785	1/2" HEX NUT	4
46	R07637	1/2 X 1 HEX BOLTS	8
47	R07868	3/8 X 1 1/2 SOCKET HD CAP SCREW	1
48	R07732	7/16 X 1 1/4 CARRIAGE BOLT	2
49	R07804	7/16 LOCK WASHER	2
50	R07797	3/8-2 UNF HEX NUT	1
51	250-76-34-256	STABILIZER SLEEVE	1

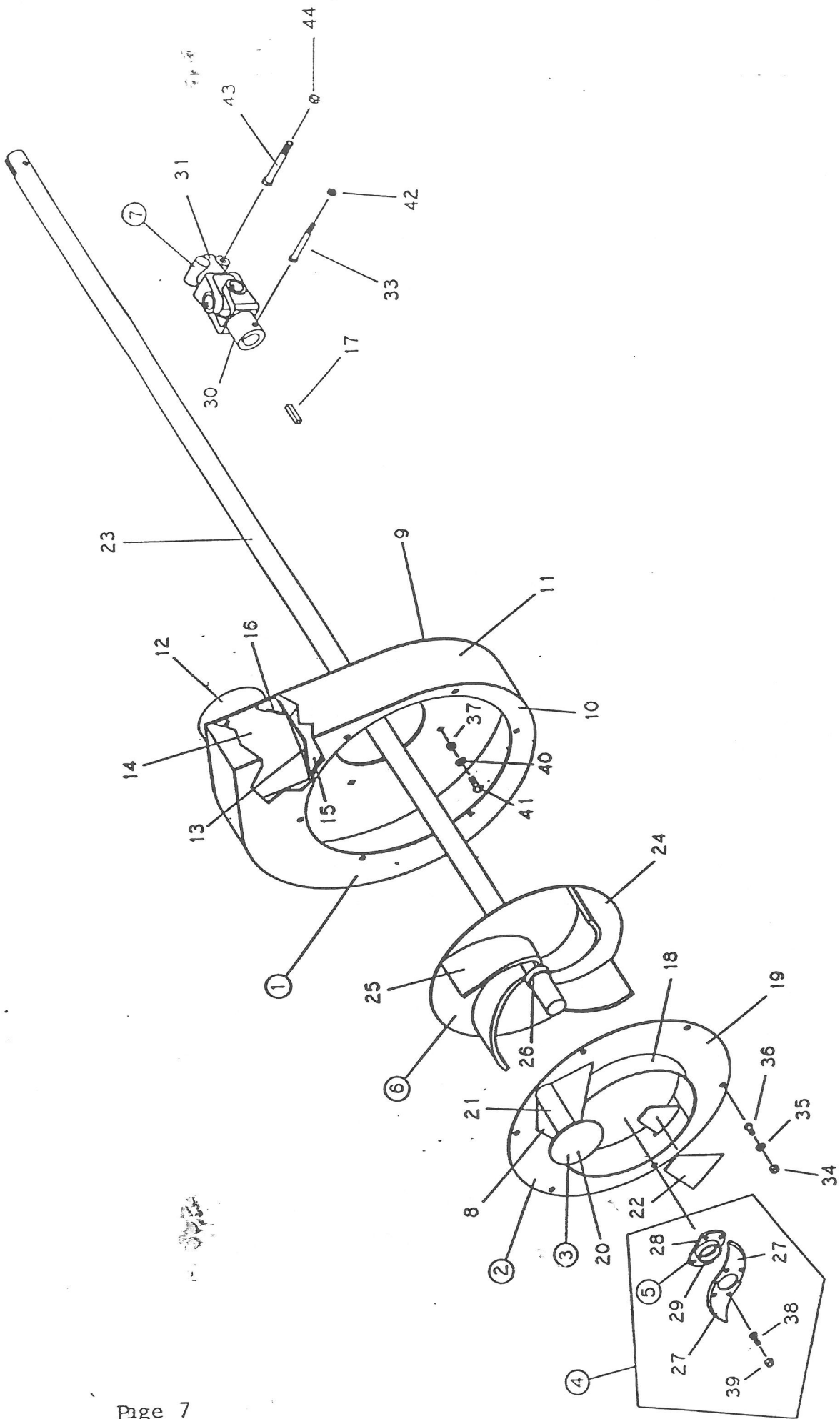

FAN AND HOUSING

KEY	PART NUMBER	DESCRIPTION	QTY
1	250-72-00-000	FAN HOUSING ASSY	1
2	250-04-00-000	COVER PLATE ASSY	1
3	250-04-03-000	FOOT ASSY	1
4	250-73-00-000	CUTTER BLADE KIT	1

5	250-73-32-000	CUTTER BLADE BRKT ASSY	1
6	250-03-11-000	IMPELLER ASSY	1
7	250-75-00-000	KNUCKLE ASSY	1
8	250-04-00-173	FOOT GUSSET	2

9	250-72-00-161	UPPER FAN HOUSING PLATE	1
10	250-72-00-162	LOWER FAN HOUSING PLATE	1
11	250-72-00-163	HOUSING BAND	1
12	250-72-00-164	DISCHARGE TUBE	1

13	250-72-00-165	SIDE PLATE	1
14	250-72-00-166	HOUSING DEFLECTOR PLATE	1
15	250-72-00-167	INNER HOUSING RING	1
16	250-72-00-169	HOUSING CORNER GUSSET	2

17	270-00-00-075	3/8 KEY - 50MM LONG	1
18	250-04-00-010	INLET RING	1
19	250-04-00-011	COVER PLATE	1
20	250-04-03-012	FOOT END	1

21	250-04-03-013	FOOT PLATE	1
22	250-04-00-015	CUTTER PLATE	1
23	250-00-00-184	DRIVE SHAFT - 8 FT MODEL	1
	252-00-00-185	DRIVE SHAFT - 10 FT MODEL	1

	254-00-00-186	DRIVE SHAFT - 12 FT MODEL	1
24	250-03-00-008	IMPELLER BACK PLATE	1
25	250-03-00-009	IMPELLER BLADE	4
26	250-03-11-018	IMPELLER GUIDE RING	1

27	270-00-00-143	CUTTER BLADE	2
28	250-73-32-172	CUTTER BLADE BRKT	1
29	250-73-32-171	CUTTER BLADE RING	1
30	250-75-00-179	1 3/4 ROUND HOLE YOKE	1

31	250-75-00-187	1 3/8 - 6 TOOTH QD YOKE	1
32	R20334	JOURNAL & BRG KIT	1
33	R07634	7/16 X 4 HEX HD BOLT	1
34	R07784	7/16 HEX NUT	7

35	R07804	7/16 LOCK WASHER	6
36	R07731	7/16 X 1 CARRIAGE BOLT	6
37	R07783	3/8 HEX NUT	8
38	R07688	3/8 X 3/4 HEX HD BOLT	4

39	R07794	3/8 FLANGE NUT	4
40	R07803	3/8 LOCK WASHER	6
41	R07721	3/8 X 1 CARRIAGE BOLT	6
42	R07891	7/16 LOCK NUT	1

43	R07849	9/16-18 X 3 HEX BOLT	1
44	R08049	9/16-18 2 WAY LOCK NUT	1

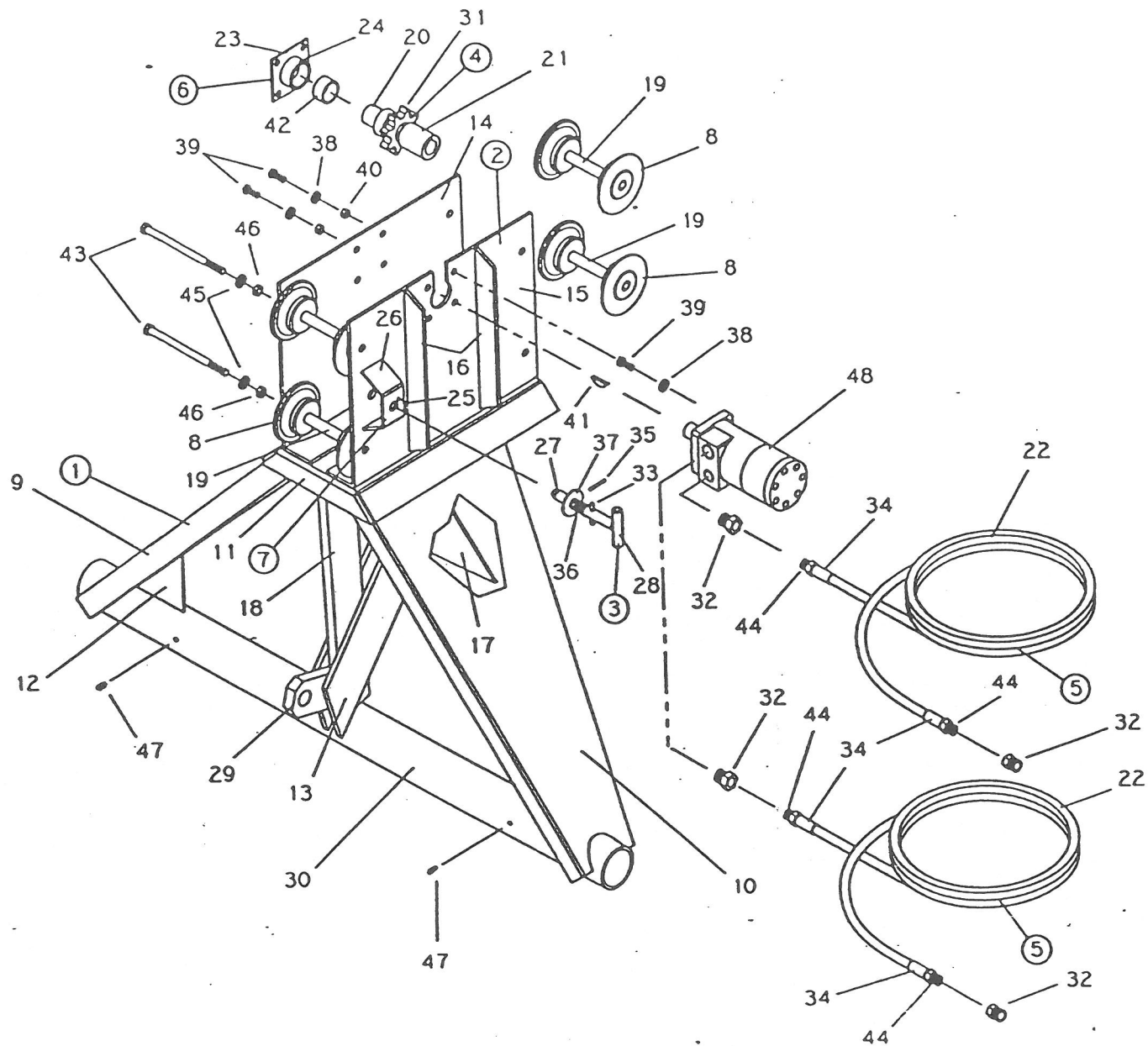

TILT FRAME

KEY	PART NUMBER	DESCRIPTION	QTY
1	250-23-00-000	TILT FRAME ASSY	1
2	250-23-20-000	L H SPOOL HOLDER ASSY	1
3	250-23-26-000	SIDE LOCK PIN ASSY	1
4	250-25-00-000	SPROCKET DRIVE ASSY	1
5	252-49-00-000	HYD HOSE ASSY	2
6	242-26-00-000	BUSHING HOLDER ASSY	1
7	242-17-17-000	SIDE LOCK BRKT ASSY	1
8	250-00-00-183	SPOOL	8
9	250-23-00-079	L H SUPPORT ARM	1
10	250-23-00-078	R H SUPPORT ARM	1
11	250-23-00-081	TILT FRAME BASE	1
12	250-23-00-082	SUPPORT ARM GUSSET	2
13	250-23-00-083	REINFORCING BAR	1
14	250-23-00-084	R H SPOOL HOLDER	1
15	250-23-20-085	L H SPOOL HOLDER	1
16	250-23-20-086	SPOOL HOLDER BRACE	2
17	250-23-00-080	TILT FRAME GUSSET	1
18	250-23-00-132	UPRIGHT SUPPORT	1
19	250-00-00-089	SPOOL SLEEVE	4
20	250-25-00-090	SPROCKET SHAFT	1
21	250-25-00-091	MOTOR TO SHAFT COUPLING	1
22	252-49-00-123	HYDRAULIC HOSE	2
23	242-26-00-133	BUSHING HOLDER PLATE	1
24	242-26-00-134	BUSHING HOLDER	1
25	242-17-17-194	PIN STOP	1
26	242-17-17-193	SIDE LOCK BRKT	1
27	250-23-26-135	SIDE LOCK PIN	1
28	242-17-18-196	PIN HANDLE	1
29	250-23-00-129	LIFT ARM	1
30	206-04-00-022	PIVOT TUBE	1
31	250-25-00-257	80B8 SPROCKET 1 1/4 BORE	1
32	R02043	1/2 X 3/8 BUSHING	4
33	R07943	3/16 X 1 1/2 ROLL PIN	1
34	R21231	STEEL FERRULES	4
35	R07950	3/16 X 1 1/4 ROLL PIN	1
36	R08027	SPRING	1
37	R07826	5/8 FLAT WASHER	1
38	R07803	3/8 LOCK WASHER	8
39	R07670	3/8 X 7/8 HEX HD BOLT	8
40	R07783	3/8 HEX NUT	8
41	R11114	DRIVE KEY COMES W/HYD MOTOR	1
42	R20259	BUSHING 1 1/4 X 1 1/2 X 3/4	1
43	R07689	7/16 X 7 HEX HD BOLT	4
44	R20804	1/2-14 NPT SOLID MALE STEM	4
45	R07804	7/16 LOCK WASHER	4
46	R07784	7/16 HEX NUT	4
47	R08183	1/4"-28 STRAIGHT GREASE FITTING	2
48	R20851	HYD MOTOR	1

KEY	PART NUMBER	DESCRIPTION	QTY
1	250-61-00-000	CHASSIS ASSY	1
2	250-62-00-000	TONGUE ASSY	1
3	250-63-00-000	TONGUE SLEEVE ASSY	1
4	250-64-00-000	AXLE ASSY	1

5	250-64-27-000	SPINDLE ASSY	2
6	250-32-00-000	PTO GUARD ASSY	1
7	250-65-00-000	TIRE AND WHEEL ASSY 5.90 X 15	2
8	242-34-00-000	HYDRAULIC HOSE ASSY	1

9	242-35-00-000	HYDRAULIC HOSE ASSY	1
10	206-03-00-000	TONGUE PIN ASSY	1
11	250-60-30-000	H-411 HUB COMPLETE	2
12	250-61-37-000	CHASSIS HITCH ASSY	1

13	206-01-01-007	BASE PIVOT	1
14	206-01-02-008	AXLE SLEEVE	2
15	206-00-00-017	AXLE TUBE	1
16	250-61-00-142	FRAME SIDE MEMBER	2

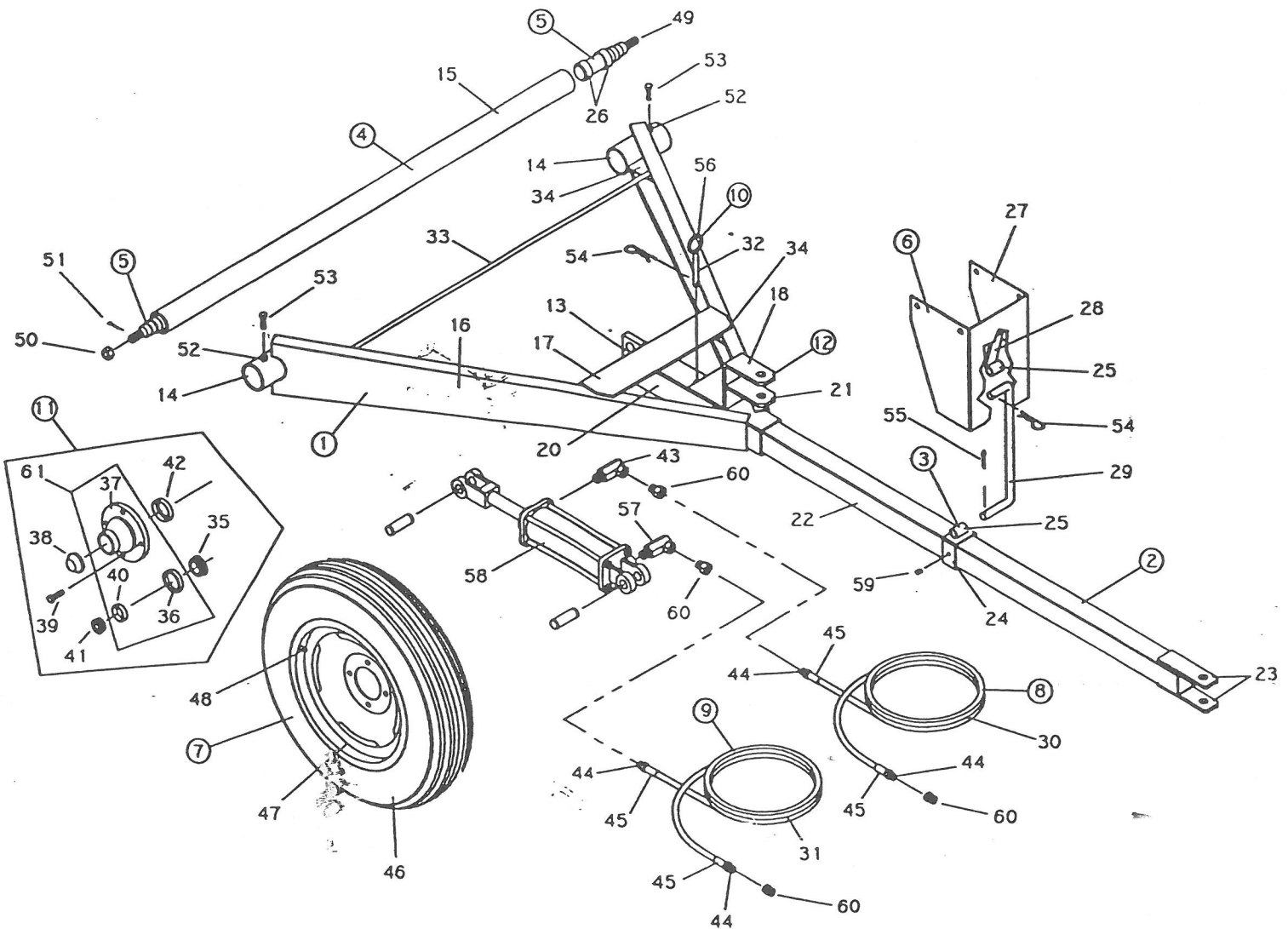

CHASSIS

<u>KEY</u>	<u>PART NUMBER</u>	<u>DESCRIPTION</u>	<u>QTY</u>
17	250-61-00-143	CROSS ANGLE	1
18	250-61-00-144	CHASSIS HITCH PLATE	1
19	250-61-00-145	CHASSIS HITCH PLATE GUSSET	2
20	250-61-00-146	HITCH PIPE	1

21	250-58-00-139	CHASSIS HITCH PLATE CENTRE	1
22	250-62-00-147	TONGUE TUBE	1
23	206-02-00-014	TONGUE PLATE	2
24	250-63-00-148	TONGUE SLEEVE	1

25	206-02-00-015	TIE ROD SLEEVE	2
26	250-64-27-149	PLUG WASHER	4
27	250-32-00-105	PTO GUARD	1
28	250-32-00-118	PTO GUARD BRACE	1

29	250-00-00-106	TIE ROD	1
30	242-34-00-158	HYDRAULIC HOSE	1
31	242-35-00-159	HYDRAULIC HOSE	1
32	206-03-00-019	TONGUE PIN	1

33	206-01-00-003	WHEEL TIE BAR	1
34	206-01-00-005	FRAME GUSSET	4
35	R20159	INNER CONE	2
36	R20129	INNER CUP	2

37	R20160	H-411 HUB	2
38	R20143	DUST CAP	2
39	R20145	WHEEL BOLTS - 1/2 -20 X 1 1/4	8
40	R20130	OUTER CUP	2

41	R20158	OUTER CONE	2
42	R20144	OIL SEAL	2
43	R21367	1/2" X 90 DEG. NPT ELBOW	1
44	R20803	3/8 SOLID MALE STEM	4

45	R21231	FERRULE 1/4" HYD HOSE	4
46	R20016	5.90 X 15 RIB IMPLIMENT TIRE	2
47	R20057	4.5 X 15 WHEEL -4 BOLT	2
48	R20020	VALVE STEM	2

49	R20141	SPINDLE W/NUT	2
50	R20142	SLOTTED HEX NUT 3/4 -16	2
51	R08002	5/32 X 1 1/2 COTTER PIN	2
52	R07784	7/16 HEX NUT	2

53	R07628	7/16 X 1 HEX HD BOLT	2
54	R07948	5/32 HAIR PIN	2
55	R08013	3/16 X 2 COTTER PIN	1
56	R07925	1/4 X 1 1/2 PLATED RING	1

57	R21335	90 DEGREE RESTRICTOR PLUG	1
58	R20727	3 X 8 HYDRAULIC CYLINDER	1
59	R07865	3/8-24 UNF SET SCREW 3/8 LONG	1
60	R02043	BUSHING 1/2 X 3/8	4

61	R20139	H-411 HUBS W/CUPS	2

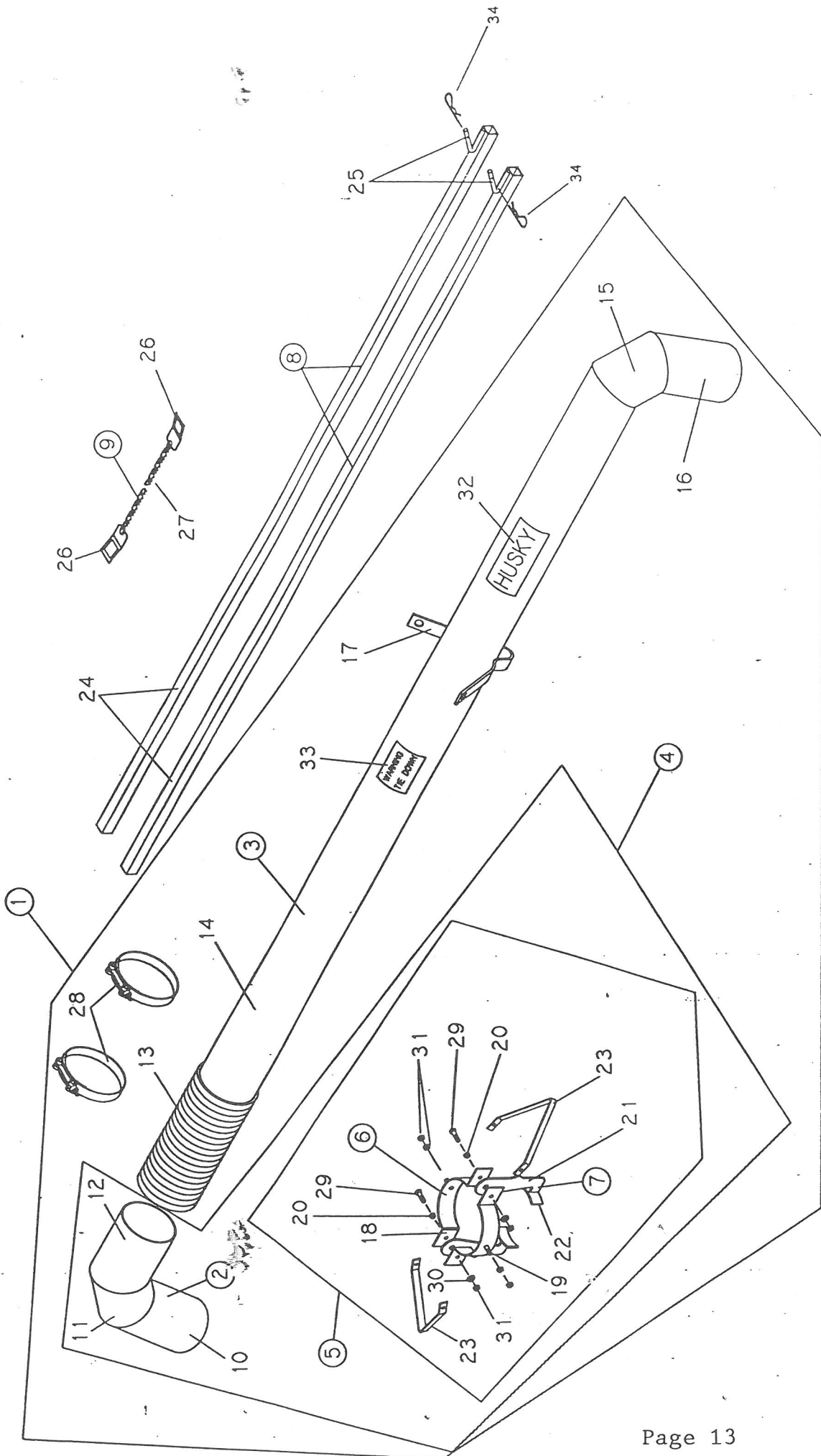

DISCHARGE PIPE

KEY	PART NUMBER	DESCRIPTION	QTY
1	250-26-00-000	DISCHARGE PIPE COMPLETE -15 FT.	1
	250-55-00-000	DISCHARGE PIPE COMPLETE - 20 FT	
2	250-26-21-000	PUMP ELBOW ASSY	1
3	250-26-22-000	DISCHARGE PIPE ASSY - 15 FT	1
	250-55-25-000	DISCHARGE PIPE ASSY - 20 FT	
4	250-52-00-000	DISCHARGE ELBOW & PIPE CONNECTOR KIT	1
5	250-50-00-000	DISCHARGE PIPE CONN - HOOK KIT	1
6	250-27-00-000	DISCHARGE PIPE SLEEVE ASSY	2
7	250-28-00-000	DISCHARGE PIPE HOOK ASSY	2
8	242-33-00-000	BIPOD LEG ASSY	2
9	242-79-00-000	BIPOD LEG CHAIN ASSY	1
10	250-26-21-092	PUMP ELBOW BASE SECTION	1
11	250-26-21-093	PUMP ELBOW MIDDLE SECTION	1
12	250-26-21-094	PUMP ELBOW UPPER SECTION	1
13	250-00-00-095	FLEXIBLE HOSE SECTION	1
14	250-26-22-096	DISCHARGE PIPE - 15 FT	1
	250-55-25-134	DISCHARGE PIPE - 20 FT	
15	250-26-22-097	DISCHARGE ELBOW CENTRE PIECE	1
16	250-26-22-098	DISCHARGE ELBOW END PIECE	1
17	250-26-22-099	DISCHARGE PIPE HOOK	1
18	250-27-00-101	DISCHARGE PIPE LOCK BRKT	2
19	242-31-00-150	REDDI ROD	2
20	242-00-00-152	HOOK SPACER	2
21	242-32-00-153	DISCHARGE PIPE LOCK HOOK	2
22	250-28-00-102	HOOK PLATE	2
23	250-00-00-103	BRACKET LOCK	2
24	242-33-00-155	BIPOD LEGS	2
25	242-33-00-156	BIPOD LEG HOOK	2
26	242-79-00-198	BIPOD LEG CLIP	2
27	242-79-00-199	BIPOD LEG CHAIN	1
28	R02482	6" SUPER CLAMP	2
29	R07611	5/16 X 1 HEX HD BOLT	2
30	R07802	5/16 LOCK WASHER	2
31	R07782	5/16 HEX NUT	6
32	R09502	HUSKY DECAL	1
33	R09690	TIE DOWN DECAL	1
34	R07948	5/32 HAIRPIN	2

KEY	PART #	MFG #	DESCRIPTION	TECH. DATA	QTY
1	R21530	3.4X010391	END YOKE	1.375-6 SPL QD	1
2	R20334	HM.234	CROSS & BEARING KIT		2
3	R21531	3.82.328X03812	YOKE & BAR ASSY.		1
4	R20378	2.1600.333	SHIELD BEARING		4

5	R21521	383333	OUTER DECAL ON ITEM 6		1
6	R21532	229244X0.3108	OUTER SHIELD		1
7	R21533	229243X0.4808	INNER SHIELD		1
8	R21523	383334	INNER DECAL ON ITEM 9		1

9	R21534	229408X0.5120	YOKE,TUBE,DBL SLV. ASSY		1
10	R20366	2.1600.193	SHIELD SUPPORT BEARING		1
11	R21535	229537X0.2	OUTBOARD SHEAR YOKE	1.375-6 SPL	1
12	R21528	229291X0	QD PIN SERVICE KIT		1

1340 SERIES PTO
R20323

