

Date Purchased _____ Machine Serial No. _____

Size of Spreader _____ Options _____

The key number system in this parts book is arranged as follows:

- ⊙ - Key numbers with two circles denotes main assemblies.
- - Key numbers with one circle are individual parts

Please order parts by number



27500L SLIMLINE SPREADER ▪ 396-00-00-000

OPERATING INSTRUCTIONS:

1. Heed all warnings.
2. Minimum HP requirements to safely operate on level terrain, on hilly terrain HP should be increased.

4500L	70 HP
7000L	85 HP
9000L	95 HP
12000L	110 HP
14000L	130 HP
15000L	140 HP
18000L	160 HP
24500L	200 HP
27500L	250 HP

3. If machine is equipped with hydraulic brakes that are operated from the tractor hydraulics, they will not work should the tractor motor stop. Inspect brakes before each use. Brakes must be bled before initial use unless installed at factory. When releasing brakes the tractor hydraulic lever must be put in the opposing position to release pressure. Do not put in float position they will not release.
4. Tractor PTO spline must be approximately 14" (355mm) from end of compressed PTO for proper adjustment
5. Hitch tanker to tractor with minimum 1-1/2" (38mm) hardened hitch pin with a safety lock. Use two - 14,000 Lbs safety chains from spreader to tractor (4:1 Safety factor on the chain minimum).
6. Do not use tongue stand to support loaded spreader. Put jack in storage position before using.
7. When hooking PTO to tractor make sure motor is stopped. Make sure QD (Quick Disconnect) safety locking pin is in locked position before using.
8. Clean off hose ends before plugging into tractor hydraulics. If spreader is equipped with hydraulic drive on spreading attachment, make sure tractor has sufficient oil flow and pressure to maintain satisfactory spread pattern, if not use another tractor.
9. After using spreader in freezing conditions make sure impeller housing is drained.

This Page is Intentionally Left Blank

OPERATING INSTRUCTIONS continued:

10. Wash tank inside and out each time work is finished. This will increase the life of the tank by many years. See item 6 of Safety instructions
11. Do not drive on public roads after dusk unless equipped with lights required by Department of Transportation in your area.
12. Remove wheels annually and grease wheel bearings.
13. Because manure smells, many farmers have made unfriendly neighbours. If in a residential area a manure injector is a recommended option to bury the smell.
14. Much of the fertilizer value of manure is lost when exposed to air. Getting the manure covered quickly is a very important part of spreading manure.
15. If rustproof coating on interior shows signs of deterioration, have interior repainted. This can be done with a roller or brush. This helps to increase the life of your spreader. It is a valuable maintenance procedure.

SAFETY INSTRUCTIONS:

Do not operate this machine until you fully understand the safe operating practices.

1. Make sure all moving parts are shielded to prevent coming in contact with loose clothing.
2. Keep children clear; do not let children or any person(s) ride the spreader at anytime.
3. Do not support loaded spreader on tongue jack.
4. Keep tire pressure to recommended pressure at all times. Recommended tire pressure being:

Size	Description	PSI	KPA
40 x 14	Airplane Tires	55	379
44 x 16	Airplane Tires	55	379
47 x 18 x 18	Airplane Tires	55	379
50 x 20 x 20	Airplane Tires	55	379
16.5L x 16.1	Implement Tires	35	241
21.5L x 16.1	Implement Tires	35	241
18.4L x 26	Turf Tires	30	207
23.1L x 26	Turf Tires	24	166
28L x 26	Turf Tires	24	166
30.5L x 32	Turf Tires	35-40	241
35.5L x 32	20 ply Turf Tires	35	241
18L x 22.5	Truck Tires	65	448
23.5L x 25	Loader Dozer Tires	55	379

5. Keep wheel bolts torqued to the recommended torque at all times. (Check Daily)

Wheel Bolt Size	Ft/Lbs Torque (Dry)	Ft/Lbs. - Oiled	Meter/Kg - Torque Dry	Meter/Kg - Oiled
9/16 – 18 NF GR. 5	120	90	16.59	12.44
5/8 – 18 NF GR. 8	240	180	33.18	24.89
3/4 – 16 NF GR. 8	420	310	58.07	42.86

6. Never enter a tanker without special breathing equipment to supply oxygen. Manure gases can kill instantly. One breath of Hydrogen Sulphide can kill.
7. When repairing hydraulic hoses, always relieve pressure in hose. Always wear safety glasses while working on spreader.
8. Caution – disc brakes will not release until valve lever is held momentarily in opposite position. This will relieve pressure in brake line. Do not put in float position, they will not release. (Rule does not apply to Husky Manure Spreaders equipped with a Knott Brake System)

27500L SLIM LINE COMPLETE

27500L SLIM LINE COMPLETE
w/ 30.5 x 32 TIRE & WHEEL ASSY
396-00-00-000

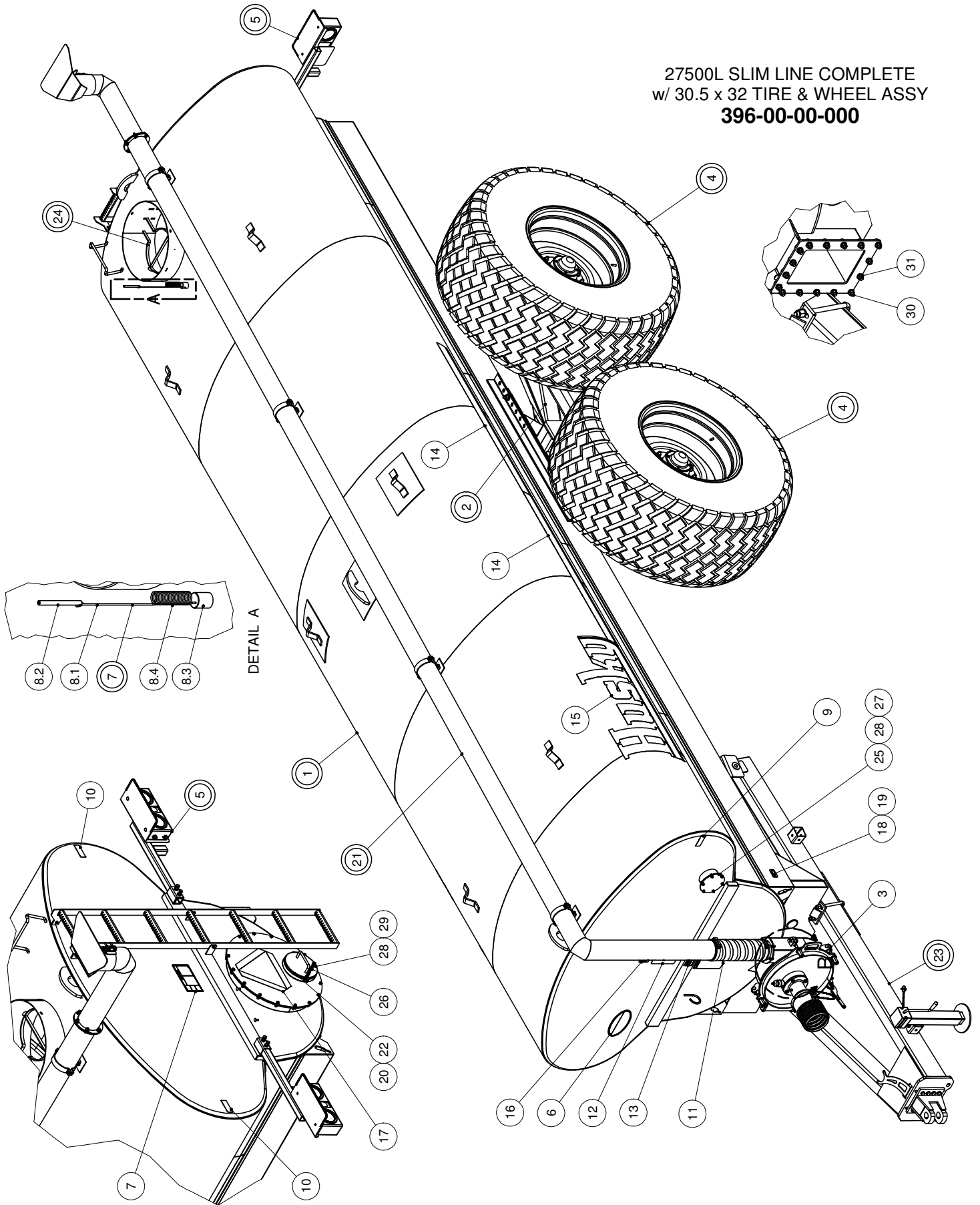

27500L SLIM LINE COMPLETE

PARTS LIST			
ITEM	PART NUMBER	DESCRIPTION	QTY
1	396-06-00-000	27500L LOW PROFILE TANK & SILL ASSY	1
2	396-01-00-000	AXLE KIT FOR 30.5 x 32 ALLIANCE RADIALS	1
3	384-51-00-000	1000 FAN & HOUSING COMPLETE-TAPERED SHAFT	1
4	356-12-00-000	30.5x32 ALLIANCE RADIAL 390 T&W	4
5	357-30-00-000	LED TAIL LIGHT KIT	1
6	R10335	MANURE SPILL DECAL	1
7	R10334	TOXIC GAS PICTORIAL DECAL	1
8	340-62-00-000	INDICATOR KIT	1
8.1	R08037	SPRING FOR SPREADER FLAG	1
8.2	340-62-00-553	INDICATOR HOSE	1
8.3	R07906	5/16-18 UNC x 0.31 SET SCREW - ZINC	1
8.4	340-00-00-536	FLAG SPRING HOLDER	1
9	R10097	AMBER REFLECTOR	1
10	R10096	RED REFLECTOR	2
11	R09783	"CAUTION" DECAL	1
12	R09730	TORQUE, TIRE PRESSURE DECAL	1
13	R09512	CAPACITY DECAL	1
14	R09511	ACCENT STRIP	4
15	R09510	"HUSKY" DECAL	2
16	R09509	"MADE IN CANADA" DECAL - LARGE	1
17	R09501	SLOW MOVING VEHICLE DECAL	1
18	R09071	SERIAL NUMBER PLATE	1
19	R08152	#6 x 1/4" PAN HD SOCKET SCREW	2
20	R02863	8" CL GASKET	1
21	396-08-00-000	6" DISCHARGE PIPE KIT	1
22	395-08-04-000	8" DRAIN PLUG ASSY	1
23	395-07-00-000	24500L & 27500L SL TONGUE KIT	1
24	357-63-00-000	SAFETY BAR ASSY	1
25	330-00-00-559	ACCESS TUBE COVER PLATE	1
26	244-09-00-000	8" CLAMP & CHAIN ASSY	1
27	R07619	3/8-16 UNC x 1 HEX BOLT GR.5	6
28	R07675	3/8-16 UNC x 1.25 HEX BOLT GR.5	1
29	R07794	3/8-16 UNC FLANGE NUT - ZINC	7
30	R07674	1/2-13 UNC x 1.25 HEX BOLT GR.5	16
31	R07795	1/2-13 UNC FLANGE NUT - ZINC	16

27500L SLIM LINE TANK ASSY

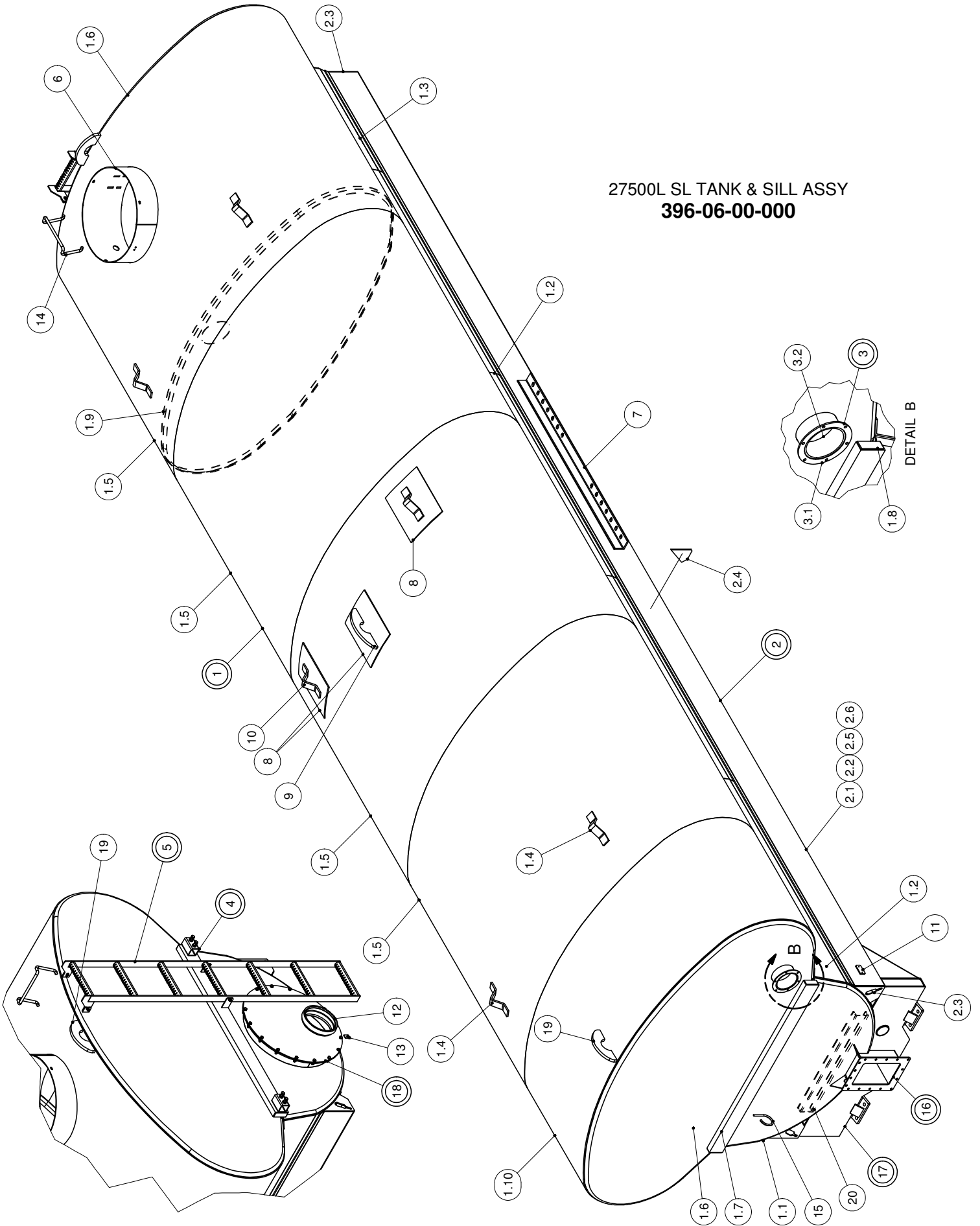

27500L SLIM LINE TANK ASSY

PARTS LIST				PARTS LIST			
ITEM	PART NUMBER	DESCRIPTION	QTY	ITEM	PART NUMBER	DESCRIPTION	QTY
1	396-06-01-000	27,500L LOW PROFILE TANK ASSY	1	3.1	330-20-03-560	ACCESS TUBE FLANGE	1
1.1	394-03-01-022	BOTTOM FLANGED END	2	3.2	330-20-03-556	ACCESS TUBE	1
1.2	394-03-01-020	BOTTOM SHELL	4	4	357-30-03-000	MOUNT BRKT ASSY	2
1.3	396-06-01-139	SHORT BOTTOM SHELL	1	5	394-07-00-000	LADDER ASSY	1
1.4	300-01-00-012	TANK LIFT HOOK	6	6	364-02-00-006	24" MANHOLE	1
1.5	395-08-01-045	TOP SHELL (LONG)	4	7	364-02-00-280	AXLE ADJUSTMENT ANGLE	2
1.6	394-03-01-021	TOP END	2	8	340-01-00-546	LIFT HOOK REINFORCING PLATE	3
1.7	394-03-01-024	TANK END STIFFENER	2	9	340-01-00-555	CENTER LIFT HOOK	1
1.8	330-66-00-258	STIFFENER END CAP	4	10	300-01-00-012	TANK LIFT HOOK	2
1.9	394-03-01-023	BAFFLE	4	11	340-01-00-498	SERIAL NO. BACK PLATE	1
1.10	396-06-01-129	TOP SHELL (SHORT)	1	12	395-08-00-051	8" DRAIN PIPE	1
2	396-06-02-000	SILL ASSY	2	13	250-96-00-298	CHAIN LUG	1
2.1	396-06-02-131	SILL	1	14	364-02-00-008	LADDER RUNG	1
2.2	396-06-02-132	2ND SILL	1	15	315-30-00-108	HYD. HOSE HOOK	1
2.3	394-03-02-030	SILL CAP	2	16	384-42-00-000	LOW FLANGED TANK OUTLET ASSY	1
2.4	396-06-02-136	SILL STIFFENER	6	17	396-06-05-000	28000 L CROSS MEMBER ASSY	1
2.5	396-06-02-135	3RD SILL	1	18	384-40-00-000	ACCESS HOLE & COVER PLATE KIT	1
2.6	396-06-02-164	INNER ANGLED SILL REINF PL	1	19	395-08-00-056	END LIFT HOOK	2
3	330-20-03-000	ACCESS TUBE ASSY	1	20	384-01-00-246	INSIDE CROSS SUPPORT CHANNEL	1

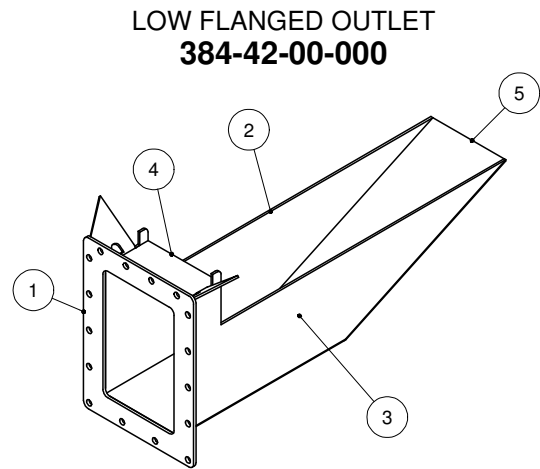
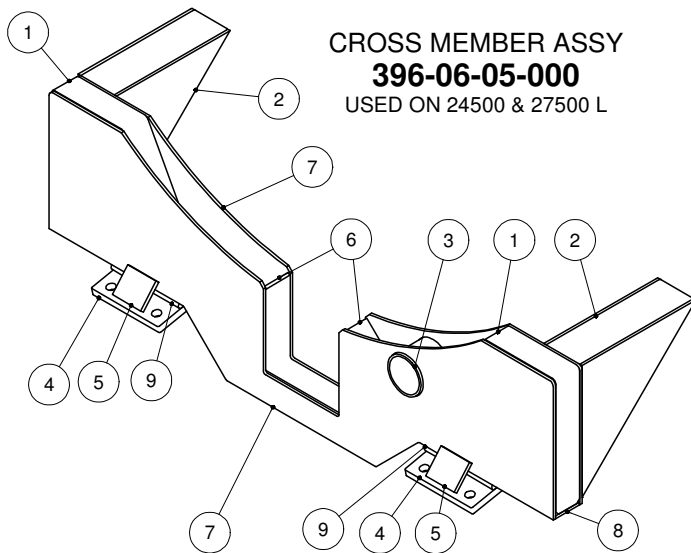

PARTS LIST			
ITEM	PART NUMBER	DESCRIPTION	QTY
1	396-06-05-142	CROSS MEMBER CAP	2
2	396-06-05-143	DOUBLE GUSSET	2
3	395-02-00-020	ACCESS TUBE	1
4	358-45-00-148	TONGUE STRAP	2
5	364-02-17-123	TONGE STRAP GUSSET	2
6	396-06-05-144	MIDDLE REINFORCING BAR	2
7	396-06-05-140	28000 L CROSS MEMBER	2
8	396-06-05-141	CROSS MEMBER BOTTOM CAP	1
9	396-06-05-146	5/8" FILLER BAR	2

PARTS LIST			
ITEM	PART NUMBER	DESCRIPTION	QTY
1	364-81-02-393	HOUSING FLANGE	1
2	384-42-00-535	LH OUTLET SIDE PC	1
3	384-42-00-536	RH OUTLET SIDE PC	1
4	364-01-03-104	OUTLET TOP PC	1
5	384-42-00-537	OUTLET BOTTOM PC	1

SLIMLINE TONGUE & HITCH KIT

21,500L - 24,500L - 27,500L - 30,500L
SLIMLINE TONGUE & HITCH KIT
395-07-00-000

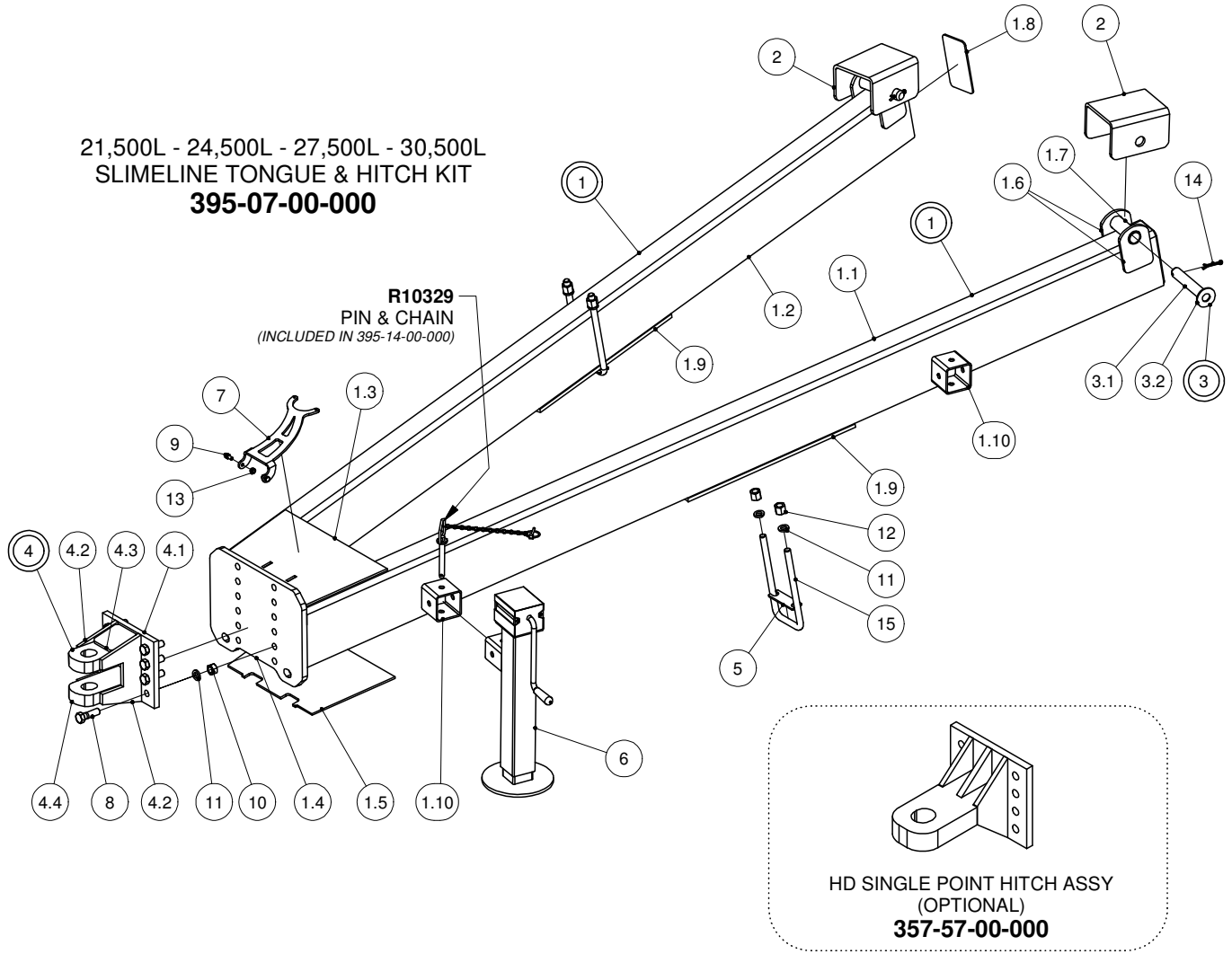

PARTS LIST				PARTS LIST			
ITEM	PART NUMBER	DESCRIPTION	QTY	ITEM	PART NUMBER	DESCRIPTION	QTY
1	395-07-01-000	24500L & 27500L SL TONGUE ASSY	1	4.1	358-43-00-139	HITCH BACK PLATE	1
1.1	395-07-01-041	L.H. TONGUE TUBE	1	4.2	358-43-00-141	HITCH SIDE GUSSET	2
1.2	395-07-01-042	R.H. TONGUE TUBE	1	4.3	358-43-00-142	HITCH UPPER GUSSET	2
1.3	357-27-00-166	UPPER TONGUE TUBE GUSSET	1	4.4	408-04-00-011	HITCH PLATE	2
1.4	358-42-00-137	HITCH BOLT PLATE	1	5	364-00-00-131	U - BOLT SPACER	2
1.5	357-27-00-310	LOWER TONGUE TUBE GUSSET	1	6	395-14-00-000	8000 Lb TONGUE JACK w/SQ TUBE & PIN	1
1.6	315-36-00-146	TONGUE SIDE PC	4	7	395-07-00-076	PTO HOLDER BRACKET	1
1.7	315-36-00-145	TONGUE BUSHING	2	8	R07655	3/4-10 UNC x 2.5 HEX BOLT GR.5	8
1.8	315-36-00-147	TONGUE TUBE COVER	2	9	R07688	3/8-16 UNC x 0.75 HEX BOLT GR.5	2
1.9	357-00-00-129	TONGUE REINFORCING PLATE	2	10	R07787	3/4-10 UNC HEX NUT - ZINC	8
1.10	395-07-01-059	TONGUE JACK OUTER BRKT	2	11	R07807	3/4 LOCK WASHER - ZINC	12
2	394-03-00-014	TONGUE "U" PC - SLIMLINE	2	12	R07820	3/4-16 UNF HIGH HEX NUT - GR.8	4
3	315-39-00-000	LOCK PIN ASSY	2	13	R07886	3/8-16 UNC 2-WAY LOCK NUT - ZINC	2
3.1	315-39-00-155	TONGUE LOCK PIN	1	14	R08016	1/4 x 2 COTTER PIN - SS	2
3.2	R07828	1 FLAT WASHER STD - ZINC	1	15	R08172	3/4" UNF x 10" - "U" BOLT	2
4	408-04-00-000	HD CLEVIS HITCH ASSY-1 3/4" HOLE	1				

24500L & 27500L TIRES

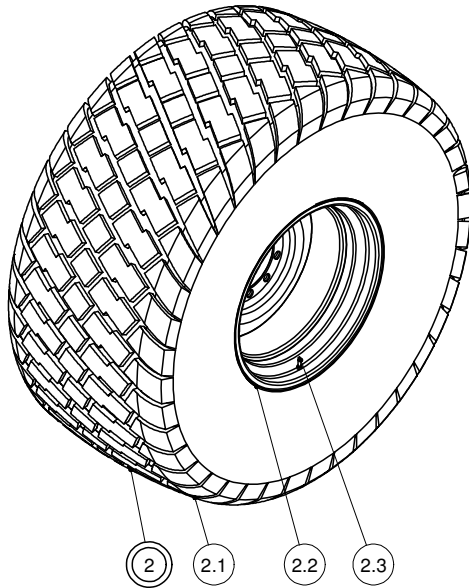

**35.5 x 32 RADIAL
TIRE & WHEEL ASSY
356-13-00-000**

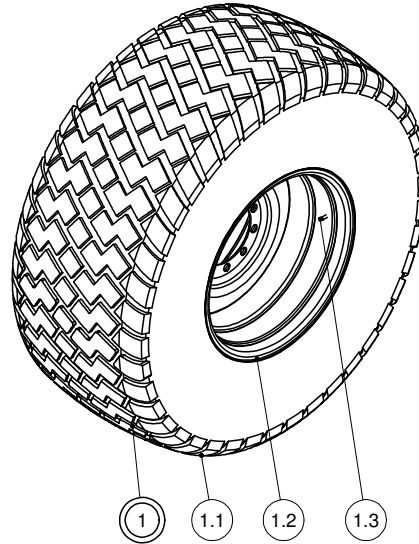

**30.5 x 32 RADIAL
TIRE & WHEEL ASSY
356-12-00-000**

PARTS LIST			
ITEM	PART NUMBER	DESCRIPTION	QTY
1	356-12-00-000	30.5x32 ALLIANCE RADIAL 390 T&W	1
1.1	R22569	30.5x32 ALLIANCE RADIAL 390 TIRE	1
1.2	R22071	DW25-26 WHEEL 13.19 BC	1
1.3	R20161	VALVE STEM	1
2	356-13-00-000	35.5L x 32 RADIAL TIRE & WHEEL ASSY - 25000LB	1
2.1	R22574	35.5x32 ALLIANCE RADIAL 390 TIRE	1
2.2	R22090	32 x 31 RIM - 11.063" PILOT 13.19 B.C.	1
2.3	R20161	VALVE STEM	1

SLIMLINE AXLE KIT - 30.5 TIRES

PARTS LIST				PARTS LIST			
ITEM	PART NUMBER	DESCRIPTION	QTY	ITEM	PART NUMBER	DESCRIPTION	QTY
1	396-01-01-000	LH TANDEM SIDE ASSY	1	2.6	396-01-01-110	FRONT OUTER GUSSET	1
1.1	396-01-02-000	LH TANDEM WALKING BEAM ASSY	1	2.7	396-01-01-111	FRONT INNER GUSSET	1
1.1.1	396-01-02-100	WALKING BEAM	1	2.8	396-01-01-114	FRONT CAP	1
1.1.2	396-01-02-101	WALKING BEAM END	2	2.9	358-01-00-401	"FRONT" PLATE	1
1.1.3	356-07-02-012	SPINDLE SLEEVE FOR 5 1/2" SPINDLE	2	3	395-01-06-000	BASE FRAME ASSY 18-27500L SL	1
1.1.4	394-01-03-017	COVER PLATE	4	3.1	330-69-01-000	SILL "Z" PLATE ASSY	2
1.1.5	394-01-03-012	WALKER SLEEVE	1	3.1.1	358-85-00-253	SILL "Z" PLATE	1
1.1.6	395-01-01-004	REINFORCING PLATE	2	3.1.2	330-69-00-550	GUSSET	2
1.1.7	396-01-02-103	OUTER SPINDLE SLEEVE GUSSET	2	3.2	394-01-13-000	CROSS AXLE EXTENSION TUBE ASSY	2
1.1.8	396-01-02-102	INNER SPINDLE SLEEVE GUSSET	2	3.2.1	394-01-13-105	LH CROSS AXLE EXT TUBE	1
1.1.9	394-01-03-056	FILLER BAR	4	3.2.2	394-01-01-002	RH CROSS AXLE EXTENSION TUBE	1
1.2	396-01-04-000	"A" FRAME ASSY	1	3.3	394-01-11-000	INNER SLEEVE ASSY	1
1.2.1	396-01-04-109	CONNECTOR TUBE	1	3.3.1	394-01-11-016	SPACER BAR	1
1.2.2	396-01-04-105	REAR TANDEM ARM	1	3.3.2	394-01-11-015	5" CHANNEL @ 9LB	1
1.2.3	396-01-04-104	FRONT TANDEM ARM	1	3.3.3	394-01-02-006	CENTER SLEEVE TUBE	1
1.2.4	358-83-01-235	WALKER SLEEVE	1	3.4	358-09-02-000	OUTER SLEEVE ASSY	2
1.2.5	396-01-04-106	GUSSET	2	3.4.1	358-85-00-251	SPACER BAR	1
1.2.6	396-01-04-138	REAR TANDEM ARM GUSSET	1	3.4.2	340-07-08-323	5" CHANNEL @ 9LB	1
1.3	396-01-01-110	FRONT OUTER GUSSET	1	3.4.3	340-07-08-322	STATIONARY SLEEVE	1
1.4	396-01-01-114	FRONT CAP	1	3.5	340-07-00-329	CROSS AXLE SUPPORT COVER PLATE	2
1.5	396-01-01-111	FRONT INNER GUSSET	1	3.6	394-01-01-003	EXTENSION TUBE CAP	2
1.6	396-01-01-112	REAR OUTER GUSSET	1	3.7	394-01-01-034	DOUBLE GUSSET	4
1.7	396-01-01-113	REAR INNER GUSSET	1	3.8	394-01-01-033	FILLER PLATE	2
1.8	396-01-01-115	REAR CAP	1	3.9	395-01-06-075	HD HANGER BRKT	2
1.9	358-01-00-401	"FRONT" PLATE	1	3.10	394-01-01-001	CROSS AXLE SUPPORT TUBE	1
2	396-01-03-000	RH TANDEM SIDE ASSY	1	3.11	395-01-06-014	REINFORCING BAR	2
2.1	396-01-05-000	RH TANDEM WALKING BEAM ASSY	1	3.12	395-01-06-015	REINFORCING "U" PC	1
2.1.1	396-01-02-100	WALKING BEAM	1	4	396-10-06-000	MAIN AXLE TUBE ASSY FOR 35.5	1
2.1.2	396-01-02-101	WALKING BEAM END	2			RADIAL AXLE	
2.1.3	356-07-02-012	SPINDLE SLEEVE FOR 5 1/2" SPINDLE	2	4.1	340-63-00-538	STOP RING	1
2.1.4	394-01-03-017	COVER PLATE	4	4.2	396-10-06-169	MAIN AXLE TUBE	1
2.1.5	394-01-03-012	WALKER SLEEVE	1	4.3	396-10-06-170	THREADED PLUG	1
2.1.6	395-01-01-004	REINFORCING PLATE	2	5	357-00-00-196	25000 LB SPINDLE	4
2.1.7	396-01-02-103	OUTER SPINDLE SLEEVE GUSSET	2	6	357-06-00-000	25000 LB HUB COMPLETE	4
2.1.8	396-01-02-102	INNER SPINDLE SLEEVE GUSSET	2	7	357-00-00-128	SPINDLE WASHER	4
2.1.9	394-01-03-056	FILLER BAR	4	8	R22047	SPINDLE NUT 2 1/2" - 12UN	4
2.2	396-01-04-000	"A" FRAME ASSY	1	9	R07987	3/8 x 3 1/2" ROLL PIN	4
2.2.1	396-01-04-109	CONNECTOR TUBE	1	10	R07655	3/4-10 UNC x 2.5 HEX BOLT GR.5	4
2.2.2	396-01-04-105	REAR TANDEM ARM	1	11	R07827	3/4 FLAT WASHER STD - ZINC	8
2.2.3	396-01-04-104	FRONT TANDEM ARM	1	12	R07878	3/4-10 UNC NYLOCK NUT - ZINC	4
2.2.4	358-83-01-235	WALKER SLEEVE	1	13	396-01-00-167	SPACER TUBE	2
2.2.5	396-01-04-106	GUSSET	2	14	375-96-00-608	RETAINING CAP	1
2.2.6	396-01-04-138	REAR TANDEM ARM GUSSET	1	15	R07808	1 LOCK WASHER - ZINC	1
2.3	396-01-01-112	REAR OUTER GUSSET	1	16	R07662	1-8 UNC x 2.5 HEX BOLT GR.5	1
2.4	396-01-01-113	REAR INNER GUSSET	1	17	R07786	5/8-11 UNC HEX NUT - ZINC	8
2.5	396-01-01-115	REAR CAP	1	18	R07927	5/8-11 UNC x 1.5 SQ HD SET SCR- BLK	8

SLIMLINE AXLE KIT - 35.5 TIRES

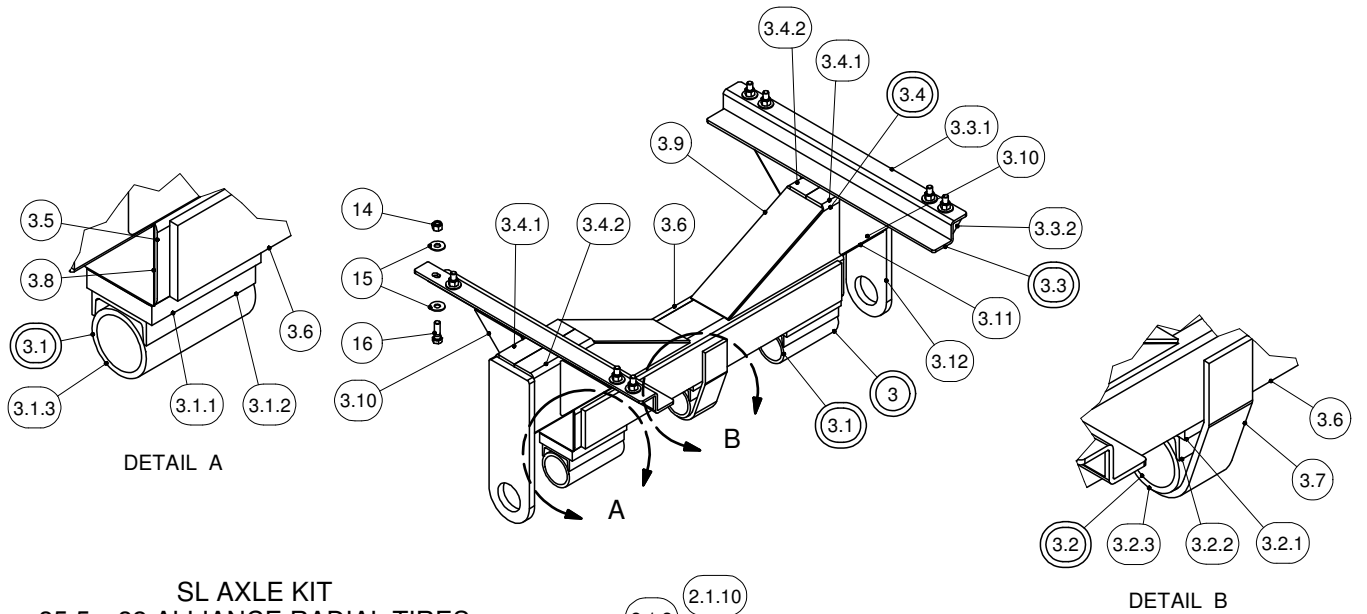

SL AXLE KIT 35.5 x 32 ALLIANCE RADIAL TIRES 396-10-00-000

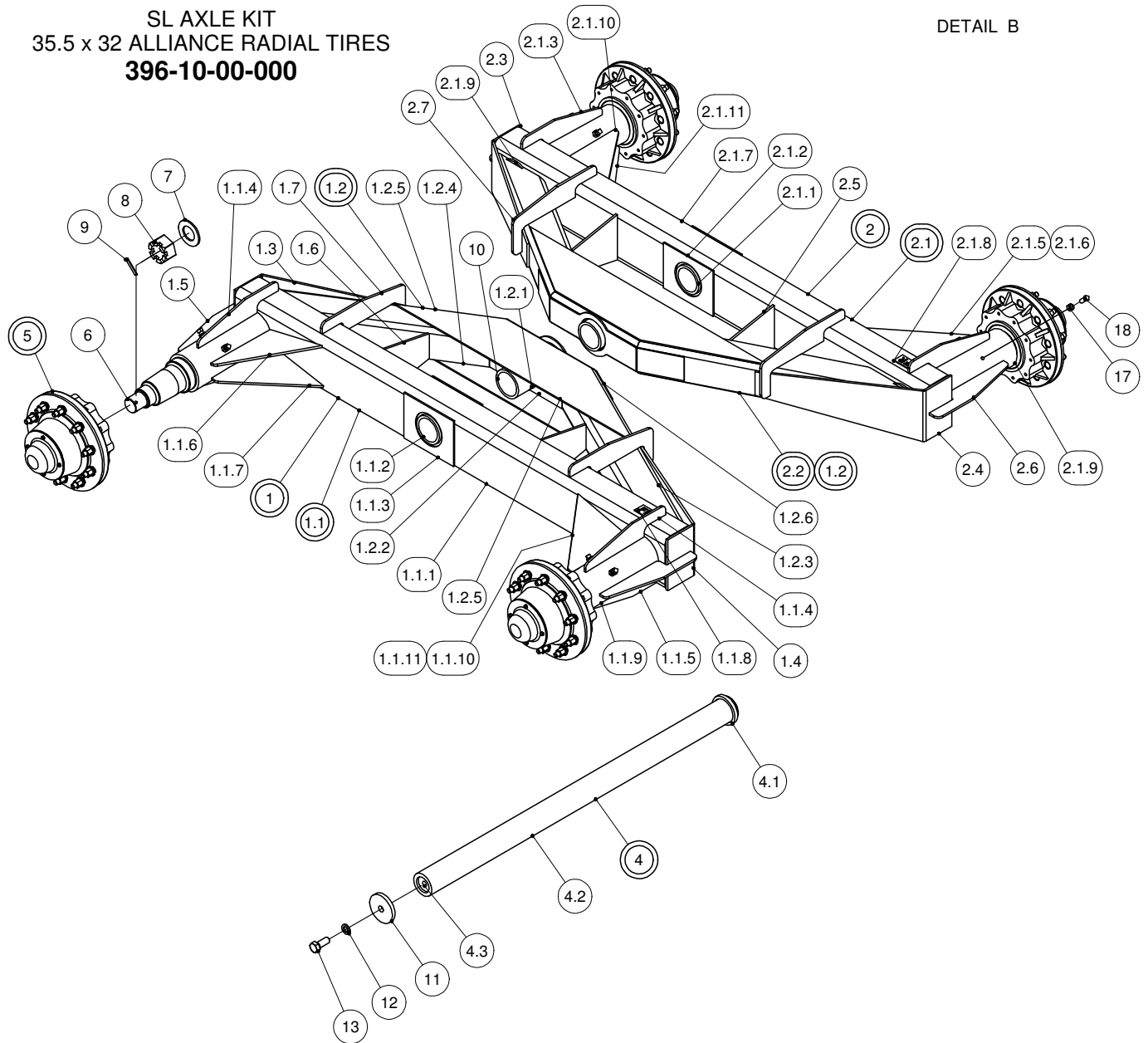

SLIMLINE AXLE KIT - 35.5 TIRES

PARTS LIST				PARTS LIST			
ITEM	PART NUMBER	DESCRIPTION	QTY	ITEM	PART NUMBER	DESCRIPTION	QTY
1	396-10-01-000.	RH TANDEM SIDE ASSY	1	2.7	396-10-01-165	TANDEM SIDE TIE PLATE	2
1.1	396-10-02-000	RH WALKING BEAM ASSY	1	3	395-01-06-000	BASE FRAME ASSY 18-27500L SL	1
1.1.1	396-10-02-148	RH WALKING BEAM	1	3.1	358-09-02-000	OUTER SLEEVE ASSY	2
1.1.2	394-01-03-012	WALKER SLEEVE	1	3.1.1	358-85-00-251	SPACER BAR	1
1.1.3	395-01-01-004	REINFORCING PLATE	2	3.1.2	340-07-08-323	5" CHANNEL @ 9LB	1
1.1.4	396-10-02-161	TOP SLEEVE GUSSET	2	3.1.3	340-07-08-322	STATIONARY SLEEVE	1
1.1.5	396-10-02-162	TOP SLEEVE GUSSET	2	3.2	394-01-11-000	INNER SLEEVE ASSY	1
1.1.6	396-10-02-158	INNER SPINDLE SLEEVE GUSSET	1	3.2.1	394-01-11-016	SPACER BAR	1
1.1.7	396-10-02-159	INNER SPINDLE SLEEVE GUSSET	1	3.2.2	394-01-11-015	5" CHANNEL @ 9LB	1
1.1.8	358-01-00-401	"FRONT" PLATE	1	3.2.3	394-01-02-006	CENTER SLEEVE TUBE	1
1.1.9	396-10-02-149	SPINDLE SLEEVE FOR 5 1/2" SPINDLE	2	3.3	330-69-01-000	SILL "Z" PLATE ASSY	2
1.1.10	396-10-02-1581	INNER SPINDLE SLEEVE GUSSET	1	3.3.1	358-85-00-253	SILL "Z" PLATE	1
1.1.11	396-10-02-1592	INNER SPINDLE SLEEVE GUSSET	1	3.3.2	330-69-00-550	GUSSET	2
1.2	396-10-03-000	A FRAME ASSY	1	3.4	394-01-13-000	CROSS AXLE EXTENSION TUBE ASSY	2
1.2.1	358-83-01-235	WALKER SLEEVE	1	3.4.1	394-01-13-105	LH CROSS AXLE EXT TUBE	1
1.2.2	396-10-03-150	CONNECTOR TUBE	1	3.4.2	394-01-01-002	RH CROSS AXLE EXTENSION TUBE	1
1.2.3	396-10-03-151	FRONT TANDEM ARM	1	3.5	394-01-01-001	CROSS AXLE SUPPORT TUBE	1
1.2.4	396-10-03-152	REAR TANDEM ARM	1	3.6	395-01-06-014	REINFORCING BAR	2
1.2.5	396-10-03-153	"A" FRAME GUSSET	2	3.7	395-01-06-015	REINFORCING "U" PC	1
1.2.6	396-10-03-156	REAR TANDEM ARM GUSSET	1	3.8	340-07-00-329	CROSS AXLE SUPPORT COVER PLATE	2
1.3	396-10-01-154	RH REAR TIE PLATE	1	3.9	394-01-01-003	EXTENSION TUBE CAP	2
1.4	396-10-01-155	RH FRONT TIE PLATE	1	3.10	394-01-01-034	DOUBLE GUSSET	4
1.5	396-10-01-157	SPINDLE SLEEVE GUSSET	2	3.11	394-01-01-033	FILLER PLATE	2
1.6	396-10-01-160	GUSSET	2	3.12	395-01-06-075	HD HANGER BRKT	2
1.7	396-10-01-165	TANDEM SIDE TIE PLATE	2	4	396-10-06-000	MAIN AXLE TUBE ASSY FOR 35.5	1
2	396-10-04-000	LH TANDEM SIDE ASSY	1			RADIAL AXLE	
2.1	396-10-05-000	LH WALKING BEAM ASSY	1	4.1	340-63-00-538	STOP RING	1
2.1.1	394-01-03-012	WALKER SLEEVE	1	4.2	396-10-06-169	MAIN AXLE TUBE	1
2.1.2	395-01-01-004	REINFORCING PLATE	2	4.3	396-10-06-170	THREADED PLUG	1
2.1.3	396-10-02-161	TOP SLEEVE GUSSET	2	5	357-06-00-000	25000 LB HUB COMPLETE	4
2.1.4	396-10-02-162	TOP SLEEVE GUSSET	2	6	357-00-00-196	25000 LB SPINDLE	4
2.1.5	396-10-02-158	INNER SPINDLE SLEEVE GUSSET	1	7	357-00-00-128	SPINDLE WASHER	4
2.1.6	396-10-02-159	INNER SPINDLE SLEEVE GUSSET	1	8	R22047	SPINDLE NUT 2 1/2" - 12UN	4
2.1.7	396-10-05-163	LH WALKING BEAM	1	9	R07987	3/8 x 3 1/2" ROLL PIN	4
2.1.8	358-01-00-401	"FRONT" PLATE	1	10	396-10-00-168	SPACER TUBE	2
2.1.9	396-10-02-149	SPINDLE SLEEVE FOR 5 1/2" SPINDLE	2	11	375-96-00-608	RETAINING CAP	1
2.1.10	396-10-02-1591	INNER SPINDLE SLEEVE GUSSET	1	12	R07808	1 LOCK WASHER - ZINC	1
2.1.11	396-10-02-160	INNER SPINDLE SLEEVE GUSSET	1	13	R07662	1-8 UNC x 2.5 HEX BOLT GR.5	1
2.2	396-10-03-000	A FRAME ASSY	1	14	R07878	3/4-10 UNC NYLOCK NUT - ZINC	8
2.3	396-10-01-154	RH REAR TIE PLATE	1	15	R07827	3/4 FLAT WASHER STD - ZINC	16
2.4	396-10-01-155	RH FRONT TIE PLATE	1	16	R07655	3/4-10 UNC x 2.5 HEX BOLT GR.5	8
2.5	396-10-01-160	GUSSET	2	17	R07786	5/8-11 UNC HEX NUT - ZINC	8
2.6	396-10-01-157	SPINDLE SLEEVE GUSSET	2	18	R07927	5/8-11 UNC x 1.5 SQ HD SET SCREW - BLK	8

25000LB HUB COMPLETE

25000LB 10 BOLT HUB COMPLETE
357-06-00-000

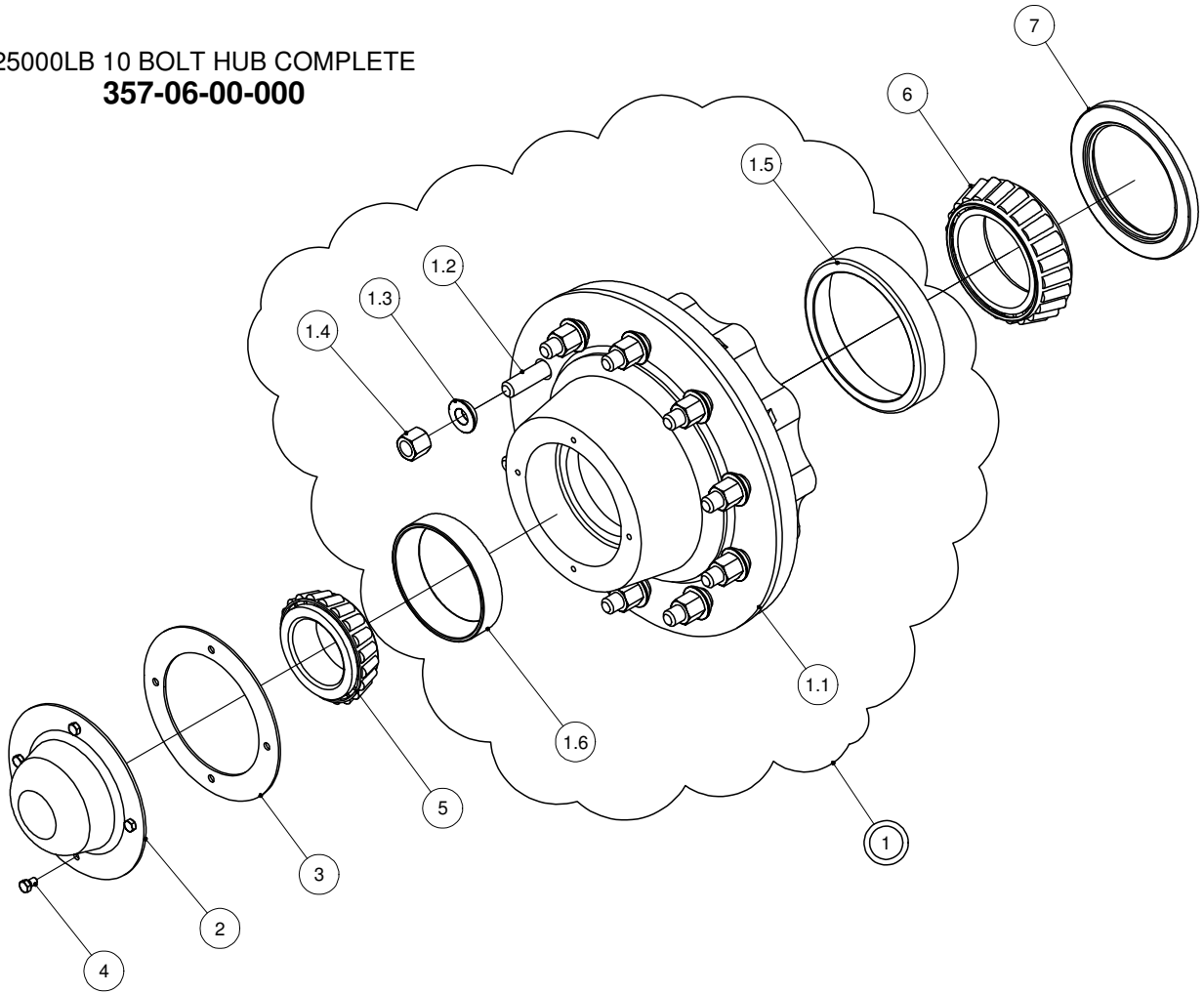

PARTS LIST			
ITEM	PART NUMBER	DESCRIPTION	QTY
1	357-06-00-215	25000LB HUB w/ CUPS,BLTS,NUTS & WSHRS	1
1.1	25000LB HUB	25000LB HUB - MACHINED LESS BEARINGS	1
1.2	R20096	3/4" WHEEL BOLTS	10
1.3	R20152	3/4" SPHERICAL WASHER	10
1.4	R07820^	3/4" FED. HIGH HEX NUT	10
1.5	R22038	INNER CUP 71750	1
1.6	R22037	OUTER CUP 653	1
2	R22041	DUST CAP - 25000LB HUB	1
3	R22042	DUST CAP GASKET	1
4	R07694	5/16-18 UNC x 0.5 HEX BOLT GR.5	4
5	R22039	OUTER CONE - 663	1
6	R22040	INNER CONE - 71455	1
7	R22045	HUB SEAL 456192	1

This Page is Intentionally Left Blank

27500L SL 6" DISCHARGE PIPE KIT

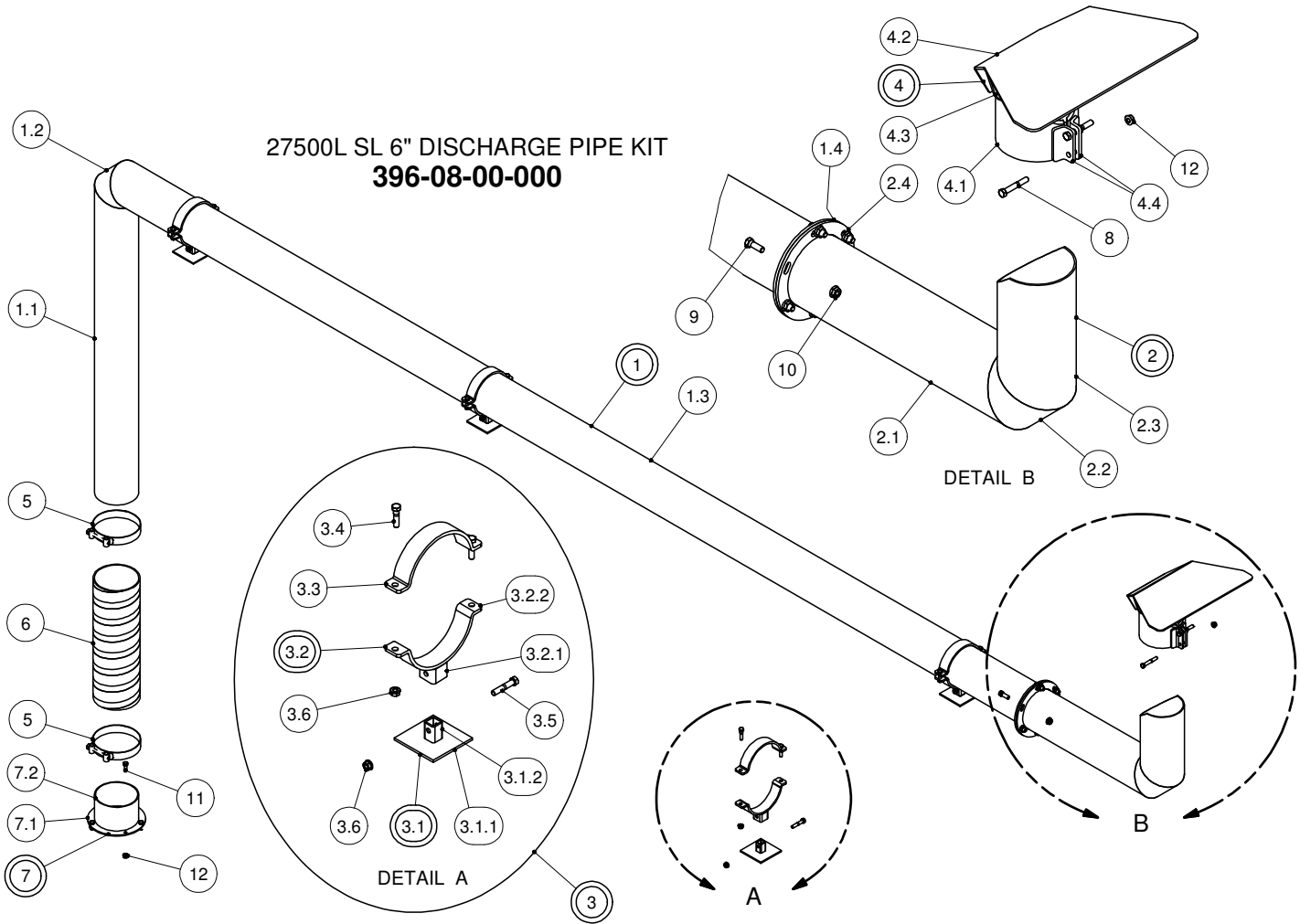

PARTS LIST				PARTS LIST			
ITEM	PART NUMBER	DESCRIPTION	QTY	ITEM	PART NUMBER	DESCRIPTION	QTY
1	396-08-01-000	6" DISCHARGE PIPE ASSY	1	3.4	R07620	3/8-16 UNC x 1.5 HEX BOLT GR.5	2
1.1	396-08-01-145	28000 L VERTICAL DISCHARGE PIPE	1	3.5	R07621	3/8-16 UNC x 2 HEX BOLT GR.5	1
1.2	364-19-00-082	DISCHARGE PIPE CORNER PC	1	3.6	R07794	3/8-16 UNC FLANGE NUT - ZINC	3
1.3	396-08-01-137	28000L 6" DISCHARGE PIPE	1	4	364-68-00-000	6" SPLASH PLATE ASSY	1
1.4	364-19-00-087	DISCHARGE PIPE FLANGE	1	4.1	364-68-00-215	CLAMPING TUBE	1
2	364-25-00-000	DISCHARGE PIPE END SECTION ASSY	1	4.2	364-21-00-069	SPLASH PLATE	1
2.1	364-25-00-088	DISCHARGE PIPE FLANGE PC	1	4.3	364-21-00-224	SPLASH PLATE WING	2
2.2	364-19-00-082	DISCHARGE PIPE CORNER PC	1	4.4	364-21-00-071	CLAMPING TUBE BRKT	2
2.3	364-25-00-067	DISCHARGE PIPE END PC	1	5	R02482	6" HOSE CLAMP	2
2.4	364-19-00-087	DISCHARGE PIPE FLANGE	1	6	364-00-00-066	HOSE SECTION	1
3	357-16-00-000	6" DISCHARGE PIPE HOLDER KIT	4	7	364-31-00-000	HOSE TUBE ASSY - 6"	1
3.1	357-16-01-000	DISCHARGE PIPE BASE HOLDER ASSY	1	7.1	364-01-03-376	DISCHARGE RING	1
3.1.1	357-16-01-130	BASE PLATE	1	7.2	364-01-03-063	DISCHARGE TUBE	1
3.1.2	357-16-01-131	LOWER STUB	1	8	R07622	3/8-16 UNC x 2.5 HEX BOLT GR.5	2
3.2	357-16-02-000	PIPE HOLDER ASSY	1	9	R07671	7/16-14 UNC x 1.25 HEX BOLT GR.5	6
3.2.1	357-16-02-137	UPPER STUB	1	10	R07879	7/16-14 UNC FLANGE NUT - ZINC	6
3.2.2	357-16-00-133	TOP PIPE HOLDER - 6"	1	11	R07619	3/8-16 UNC x 1 HEX BOLT GR.5	5
3.3	357-16-00-133	TOP PIPE HOLDER - 6"	1	12	R07794	3/8-16 UNC FLANGE NUT - ZINC	7

27500L SL 8" DISCHARGE PIPE KIT

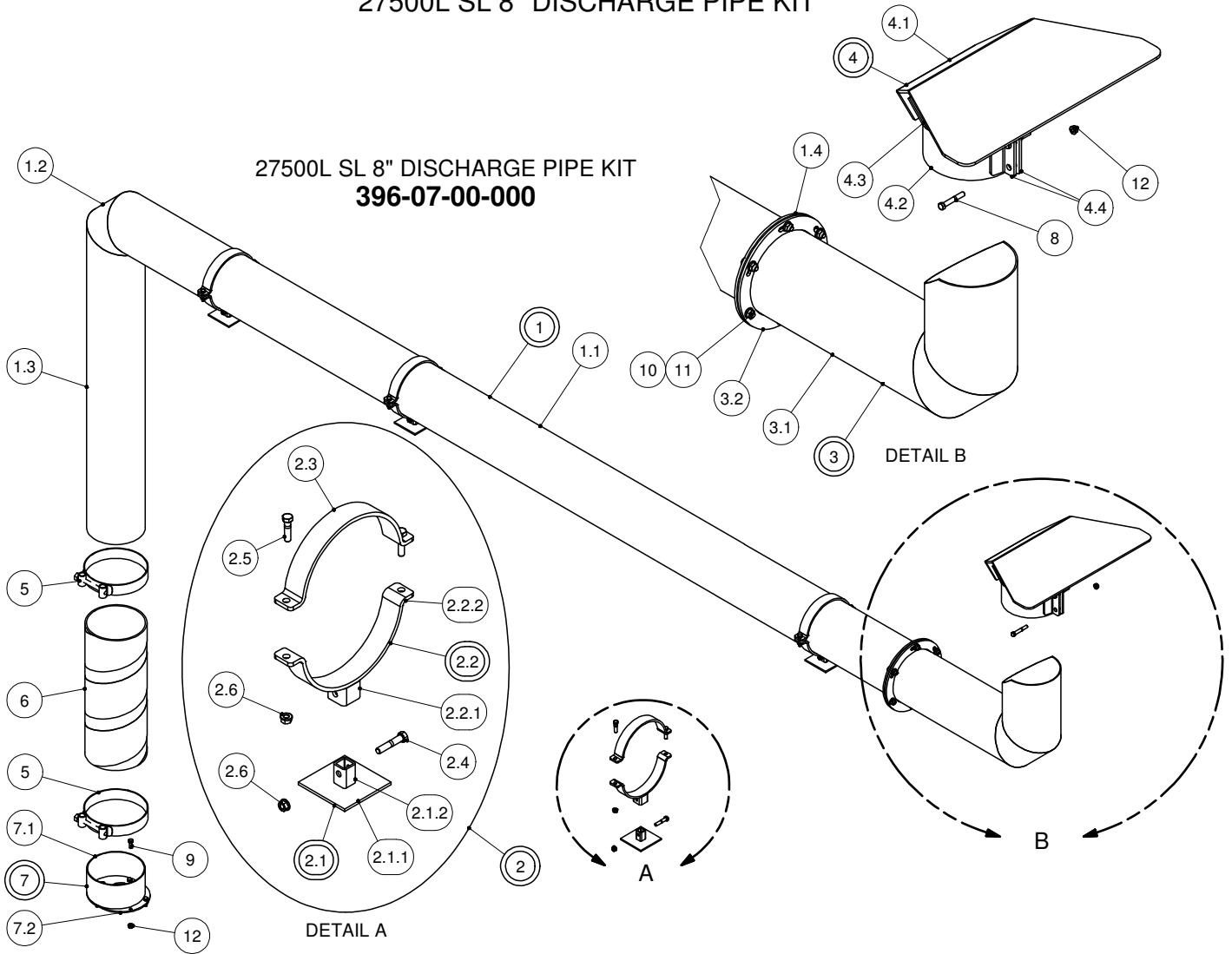

PARTS LIST				PARTS LIST			
ITEM	PART NUMBER	DESCRIPTION	QTY	ITEM	PART NUMBER	DESCRIPTION	QTY
1	396-07-01-000	28000L SL 8" DISCHARGE PIPE ASSY	1	3.1	358-92-03-307	8" EXTENSION PIPE	1
1.1	396-07-01-133	28000L 8" DISCHARGE PIPE	1	3.2	358-92-02-306	8" DISCHARGE FLANGE	1
1.2	358-92-02-524	DISCHARGE ELBOW PC	1	4	358-92-04-000	8" SPLASH PLATE ASSY	1
1.3	396-07-01-134	28000L 8" VERTICAL DISCHARGE PIPE	1	4.1	358-92-04-308	8" SPLASH PLATE	1
1.4	358-92-02-306	8" DISCHARGE FLANGE	1	4.2	358-92-04-309	8" SPLASH PLATE TUBE	1
2	357-17-00-000	8" DISCHARGE PIPE HOLDER KIT	4	4.3	358-92-04-310	WING FOR 8" SPLASH PLATE	2
2.1	357-16-01-000	DISCHARGE PIPE BASE HOLDER ASSY	1	4.4	358-92-04-311	CLAMPING TUBE BRKT	2
2.1.1	357-16-01-130	BASE PLATE	1	5	R02484	8" SUCTION HOSE CLAMP	2
2.1.2	357-16-01-131	LOWER STUB	1	6	358-92-00-329	8" DISCHARGE HOSE	1
2.2	357-17-01-000	PIPE HOLDER ASSY - 8"	1	7	358-92-01-000	8" HOUSING RING & TUBE ASSY	1
2.2.1	357-16-02-137	UPPER STUB	1	7.1	358-92-01-302	8" HOUSING OUTLET TUBE	1
2.2.2	357-17-00-135	TOP PIPE HOLDER - 8"	1	7.2	358-92-01-301	8" HOUSING DISCHARGE RING	1
2.3	357-17-00-135	TOP PIPE HOLDER - 8"	1	8	R07622	3/8-16 UNC x 2.5 HEX BOLT GR.5	2
2.4	R07621	3/8-16 UNC x 2 HEX BOLT GR.5	1	9	R07619	3/8-16 UNC x 1 HEX BOLT GR.5	5
2.5	R07620	3/8-16 UNC x 1.5 HEX BOLT GR.5	2	10	R07671	7/16-14 UNC x 1.25 HEX BOLT GR.5	6
2.6	R07794	3/8-16 UNC FLANGE NUT - ZINC	3	11	R07879	7/16-14 UNC FLANGE NUT - ZINC	6
3	358-92-03-000	8" EXTENSION PIPE ASSY	1	12	R07794	3/8-16 UNC FLANGE NUT - ZINC	7

FAN & HOUSING COMPLETE-TAPERED SHAFT

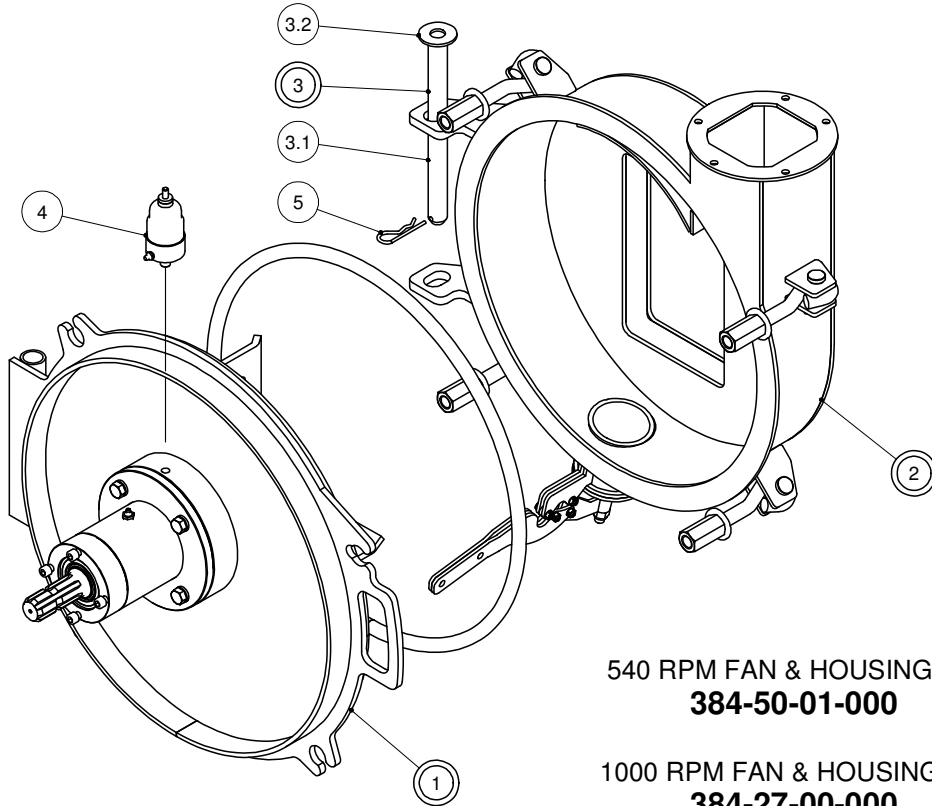

540 RPM FAN & HOUSING KIT
384-50-01-000

1000 RPM FAN & HOUSING KIT
384-27-00-000

PARTS LIST				PARTS LIST			
ITEM	PART NUMBER	DESCRIPTION	QTY	ITEM	PART NUMBER	DESCRIPTION	QTY
1	384-50-01-000	540 RPM FAN & COVER PLATE -TAPERED SHAFT	1	3	376-02-04-000	LID PIN ASSY	1
	384-27-00-000	1000 RPM FAN & COVER PLATE -TAPERED SHAFT	1	3.1	376-02-04-508	LID PIN	1
				3.2	R07827	3/4 FLAT WASHER STD - ZINC	1
				4	R10595	SPRING PRESSURE AUTO GREASE CUP	1
2	384-20-01-000	HOUSING ASSY-CHT(2007)	1	5	R07948	5/32 HAIR PIN	1
				6	R08368	3/8-16 UNC x 2.25 SHCS - BLK	2

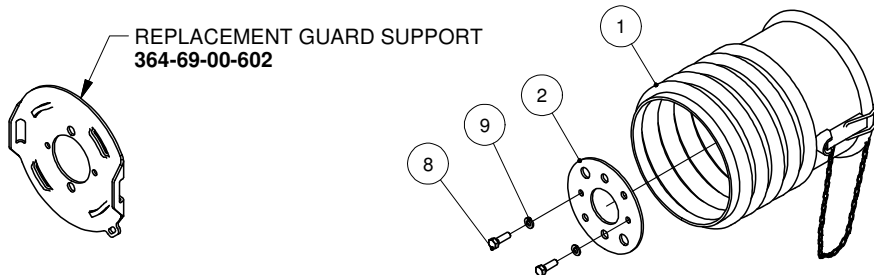

PLASTIC PTO GUARD KIT
364-69-00-000

PARTS LIST				PARTS LIST			
ITEM	PART NUMBER	DESCRIPTION	QTY	ITEM	PART NUMBER	DESCRIPTION	QTY
1	R22196	SHEILD CONE ASSY	1	8	R07611	5/16-18 UNC x 1 HEX BOLT GR.5	2
2	364-00-00-448	PTO GUARD SUPPORT	1	9	R07802	5/16 LOCK WASHER - ZINC	2

COVER PLATE-TAPERED SHAFT

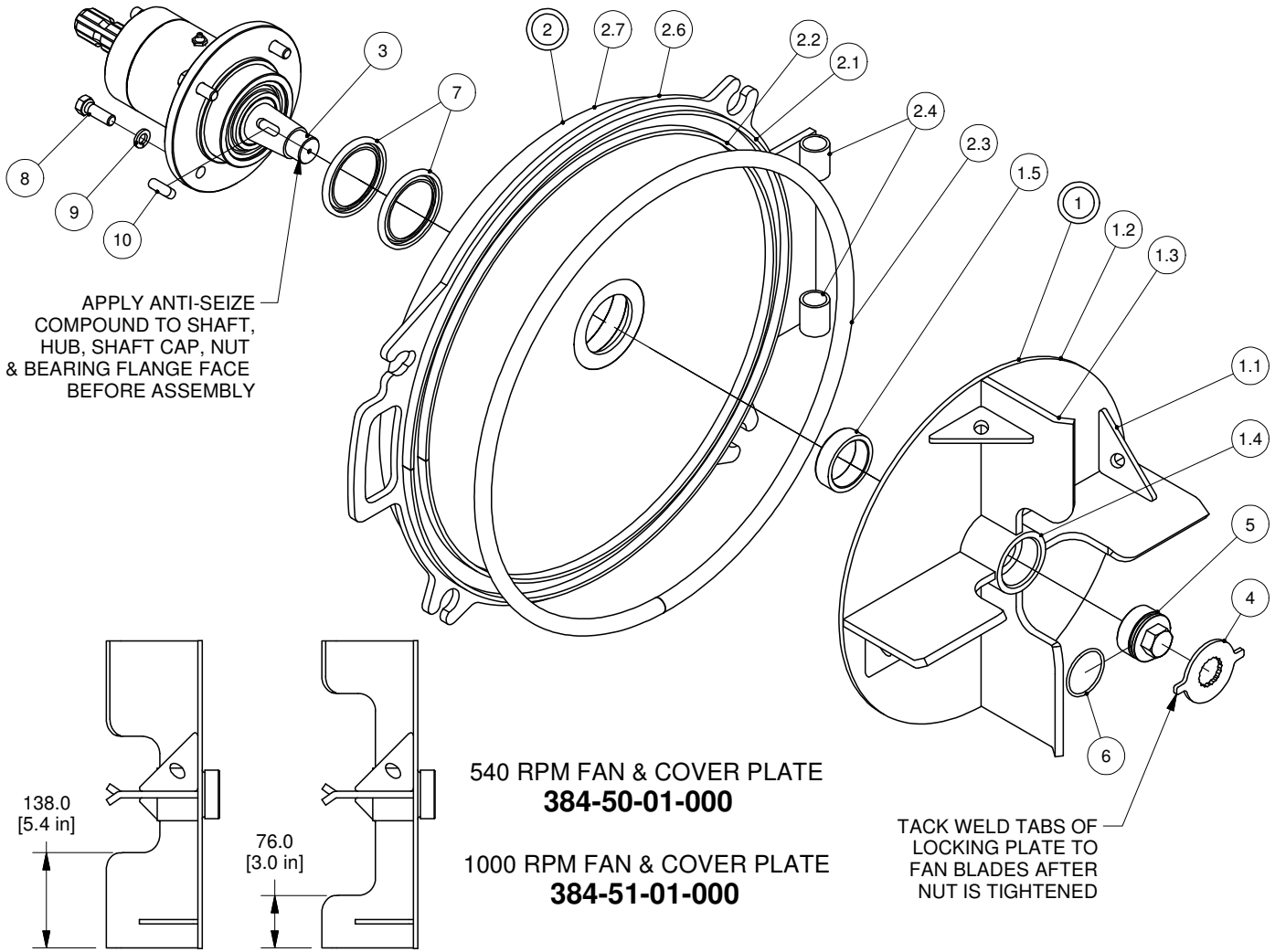

APPLY ANTI-SEIZE COMPOUND TO SHAFT, HUB, SHAFT CAP, NUT & BEARING FLANGE FACE BEFORE ASSEMBLY

TACK WELD TABS OF LOCKING PLATE TO FAN BLADES AFTER NUT IS TIGHTENED

540 RPM FAN & COVER PLATE
384-50-01-000
1000 RPM FAN & COVER PLATE
384-51-01-000

- NOTES:
- ALWAYS GREASE SEALS AND SHAFT COLLAR BEFORE INSTALLATION
 - ENSURE SEAL LIPS DO NOT "FOLD OVER" DURING ASSEMBLY

PARTS LIST				PARTS LIST			
ITEM	PART NUMBER	DESCRIPTION	QTY	ITEM	PART NUMBER	DESCRIPTION	QTY
1	384-50-02-000	TAPERED HUB FAN ASSY - 540 RPM CHT	1	2.5	384-50-03-642	MOTOR & BEARING BOX MOUNT	1
	384-51-02-000	TAPERED HUB FAN ASSY-1000 RPM CHT	1	2.6	384-50-03-641	COVER PLATE-TAPERED SHAFT	1
1.1	364-72-00-422	FAN BLADE GUSSET	4	2.7	384-27-02-534	REIN. RING-1000 RPM COVER PLATE	1
1.2	384-33-03-417	FAN BACK PLATE	1	3	384-50-04-000	BEARING KIT 1-3/8"-6T - TAPERED SHAFT	1
1.3	384-33-03-419	CHT 540 RPM FAN BLADE	4	4	384-50-01-647	TAPERED HUB LOCKING PLATE	1
1.4	384-50-02-639	TAPERED IMPELLER HUB	1	5	384-50-01-648	TAPERED SHAFT CAP NUT	1
1.5	R23443	HARDENED SEAL COLLAR - 2.75" OD	1	6	R23444	O-RING #226 - 2.25" OD x 2" ID	1
2	384-50-03-000	COVER PLATE ASSY - TAPERED SHAFT	1	7	R23441	GREASE SEAL HM21 - 2.750" x 3.751" x .25"	2
2.1	384-20-03-295	OUTER RING	1	8	R07638	1/2-13 UNC x 1.5 HEX BOLT GR.5	4
2.2	384-20-03-296	INNER RING	1	9	R07805	1/2 LOCK WASHER - ZINC	4
2.3	384-20-00-301	RUBBER SEAL	1	10	R23507	MACHINE KEY - 7/16" SQ x 1-1/4"	1
2.4	384-20-03-570	HATCH PIN SLEEVE	2				

BEARING KIT-TAPERED SHAFT

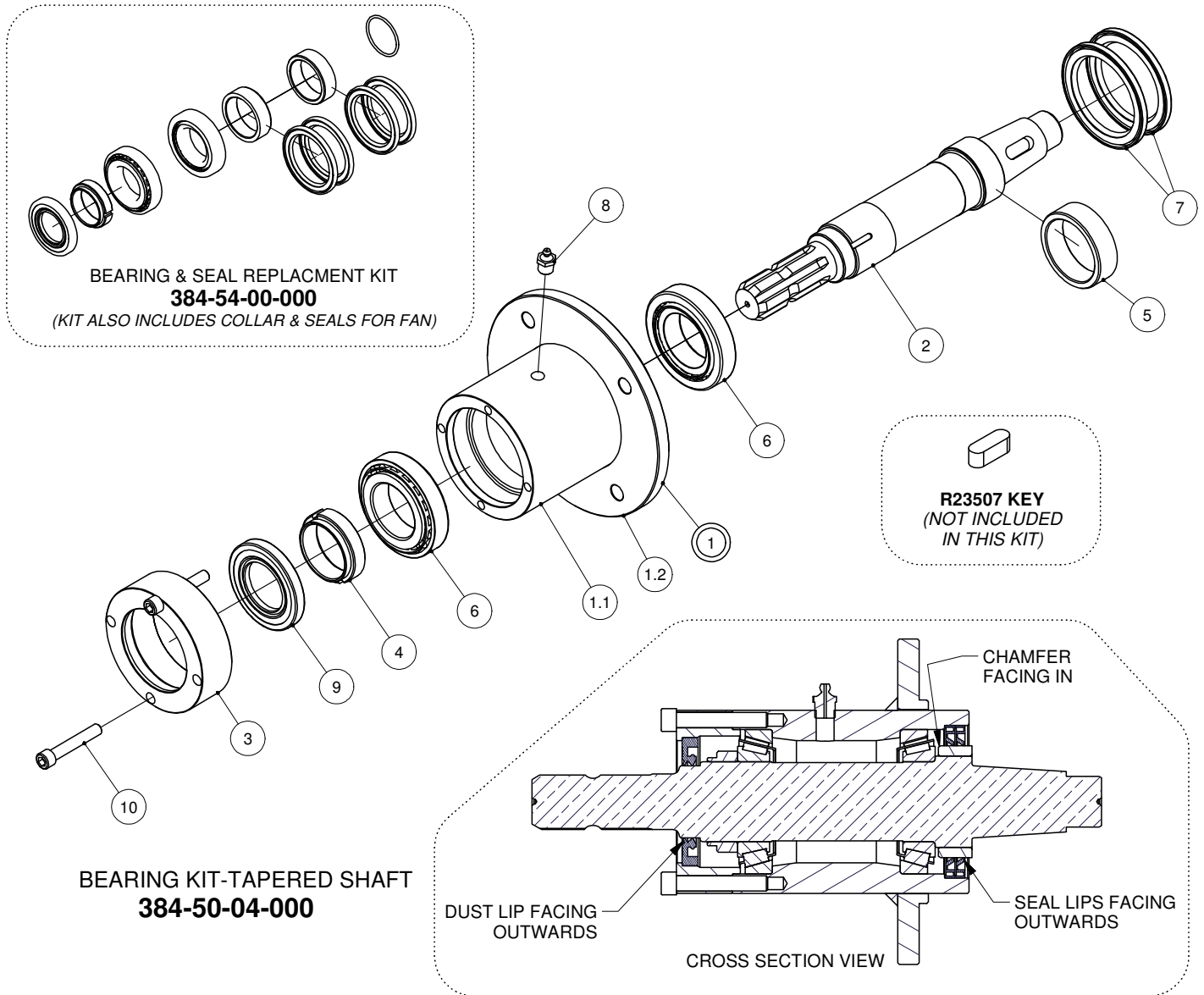

PARTS LIST			
ITEM	PART NUMBER	DESCRIPTION	QTY
1	384-50-05-000	BEARING TUBE ASSY-TAPERED SHAFT	1
1.1	384-50-05-643	TAPERED SHAFT BEARING TUBE	1
1.2	384-50-05-644	BEARING TUBE FLANGE	1
2	384-50-04-637	TAPERED FAN SHAFT - 1-3/8"-6T	1
3	384-50-04-645	TAPERED SHAFT BEARING TUBE CAP	1
4	384-50-04-646	STAKE NUT - M50-1.5	1
5	R23443	HARDENED SEAL COLLAR - 2.75" OD	1
6	R23429	TAPERED ROLLER BEARING - 50 x 90 x 21.75	2
7	R23441	GREASE SEAL HM21 - 2.750" x 3.751" x .25"	2
8	R08188	1/4" NPT STRAIGHT GREASE FTG	1
9	R23442	SEAL D.L. - 45 x 80 x 10 HMSA10 RG	1
10	R08368	3/8-16 UNC x 2.25 SHCS - BLK	2

SWING AWAY HOUSING ASSY-CHT

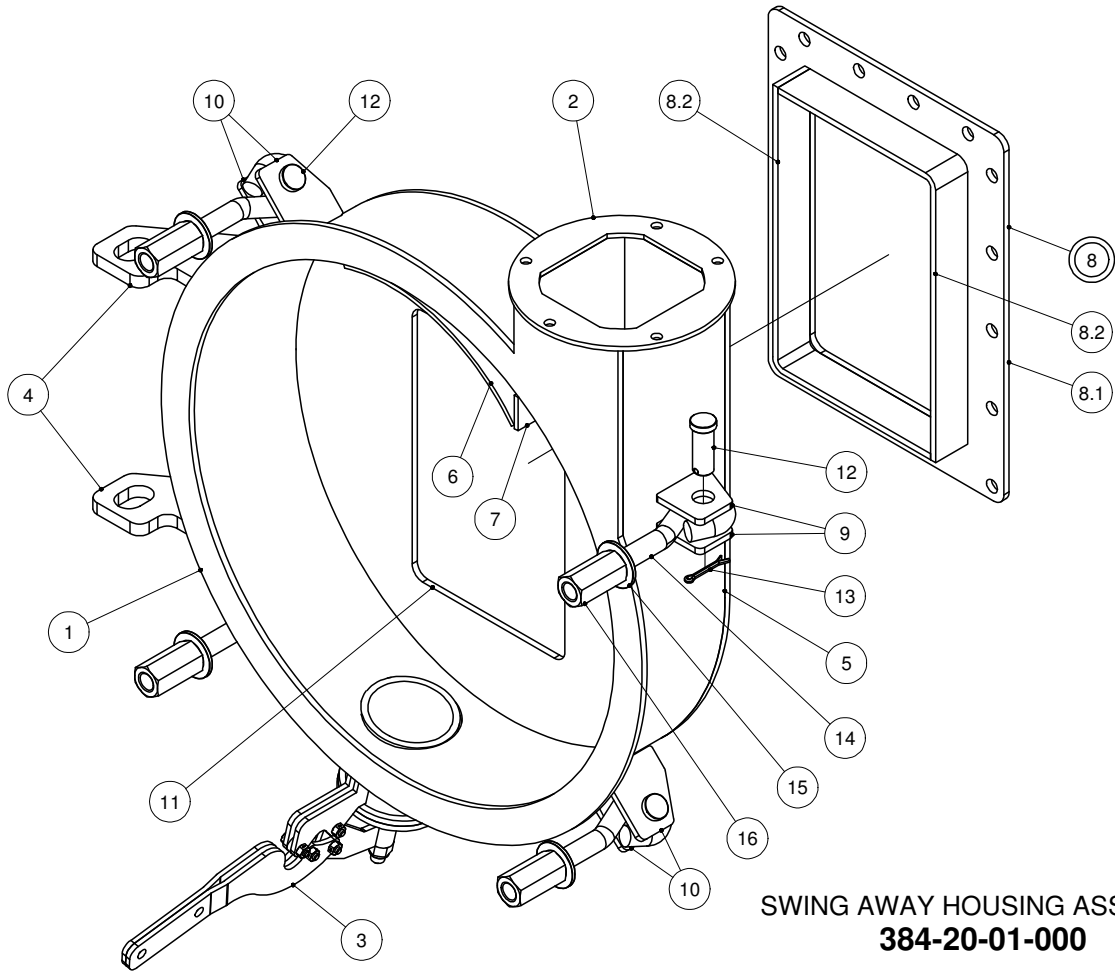

SWING AWAY HOUSING ASSY-CHT
384-20-01-000

PARTS LIST			
ITEM	PART NUMBER	DESCRIPTION	QTY
1	384-20-01-289	HOUSING FLANGE	1
2	364-01-03-376	DISCHARGE RING	1
3	364-62-00-000	DRAIN PLUG KIT	1
4	384-20-01-290	DOOR HINGE	2
5	357-48-01-232	CHT HOUSING BAND	1
6	357-48-01-231	CHT HOUSING BAND AID	1
7	357-48-01-230	CHT FAN HOUSING VERTICAL PC	1
8	357-48-02-000	CHT HOUSING INLET FLANGE ASSY	1
8.1	364-81-02-393	HOUSING FLANGE	1
8.2	357-48-02-233	CHT INLET EXTENSION	2
9	384-20-01-424	SHORT HOUSING LUG	2
10	384-20-01-423	HOUSING LUG	6
11	357-48-01-228	CHT HOUSING BACK PLATE	1
12	R08443	EYE BOLT PIN	4
13	R08207	5/32 x 1 1/2 COTTER PIN - SS	4
14	R08442	3/4" EYE BOLT	4
15	376-02-00-577	MANWAY WASHER	4
16	R07800	3/4-10 UNC COUPLING NUT - ZINC	4

HYD FAN & HOUSING COMPLETE -TAPERED SHAFT 26 GPM

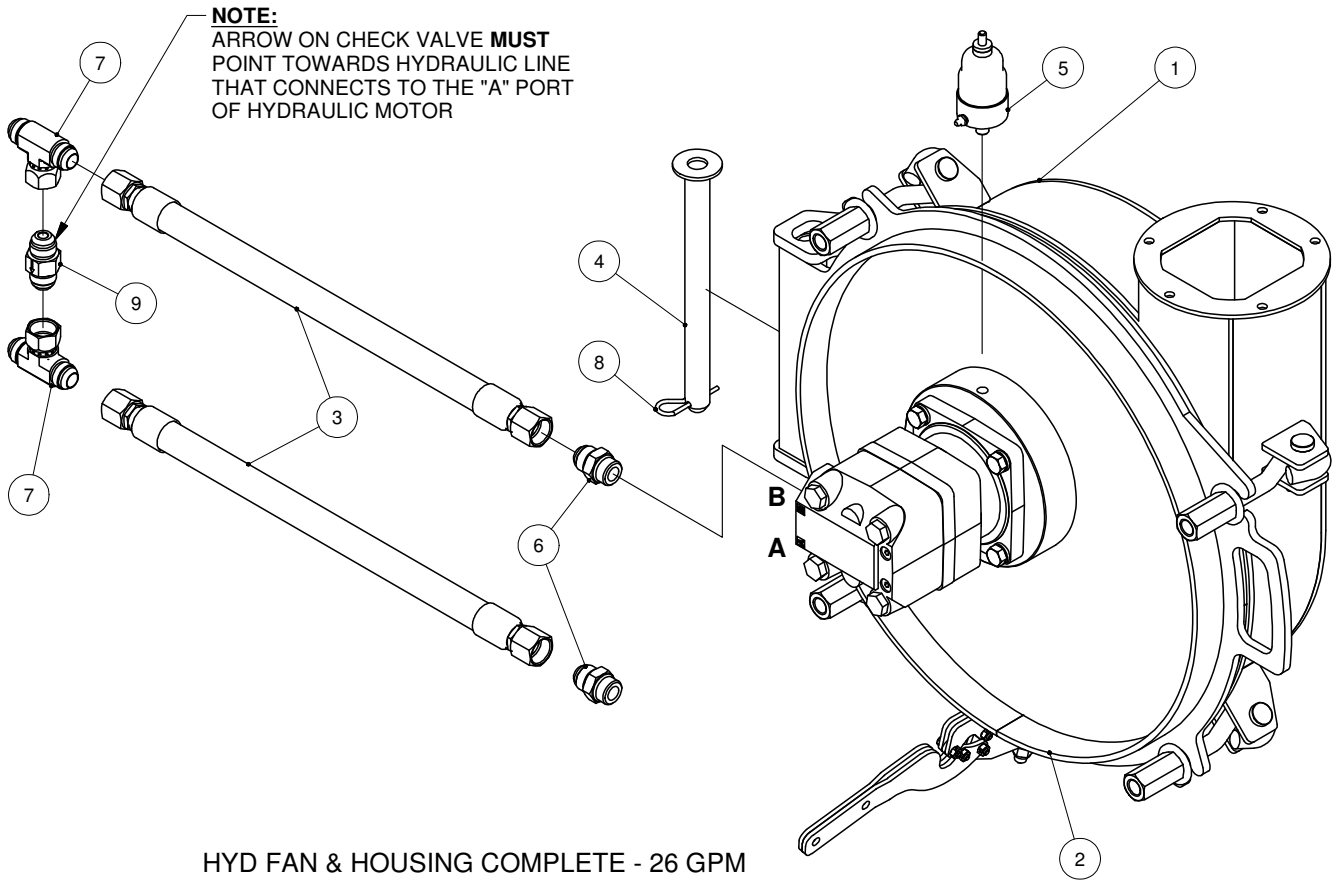

R23512
REPLACEMENT SEAL KIT FOR MLHT160T4A
HYD MOTOR w/ TAPERED SHAFT

PARTS LIST			
ITEM	PART NUMBER	DESCRIPTION	QTY
1	384-20-01-000	HOUSING ASSY-CHT(2007)	1
2	384-52-01-000	HYD FAN & COVER PLATE-TAPERED SHAFT-26 GPM	1
3	384-35-03-000	3/4" HYDRAULIC HOSE ASSY	2
4	376-02-04-000	LID PIN ASSY	1
5	R10595	SPRING PRESSURE AUTO GREASE CUP	1
6	R23098	ORB-12 x 3/4" JIC M. ADAPTOR	2
7	R23122	3/4" M. x 3/4" M. x 3/4" SW F. JIC TEE	2
8	R07948	5/32 HAIR PIN	1
9	R23447	3/4" M. JIC CHECK VALVE	1

HYD FAN & COVER PLATE-TAPERED SHAFT

M&S MLHT160 26.4 MAX GPM } 2900 MAX PSI
 M&S MLHT200 33 MAX GPM }

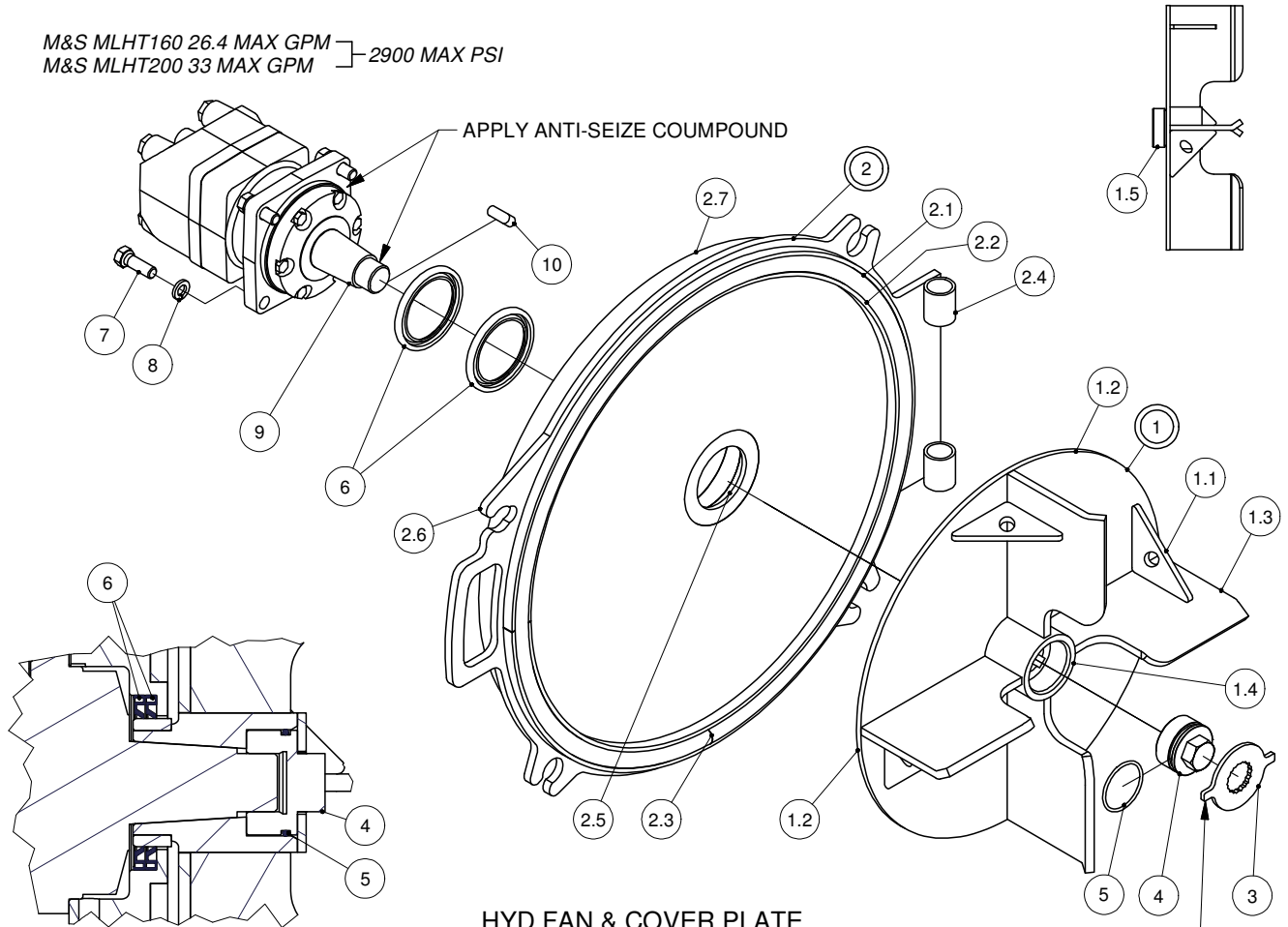

SEAL DETAIL
 SEAL LIP MUST FACE
 AWAY FROM HYD MOTOR

HYD FAN & COVER PLATE
384-52-01-000 - 26 GPM

HYD FAN & COVER PLATE
384-55-01-000 - 33 GPM

TACK WELD TABS
 OF LOCKING PLATE
 TO FAN BLADES AFTER
 NUT HAS BEEN TIGHTENED

R23512
 REPLACEMENT SEAL KIT FOR MLHT160/200T4A
 HYD MOTOR W/ TAPERED SHAFT

NOTES:

- ALWAYS GREASE SEALS AND SHAFT COLLAR BEFORE INSTALLATION
- ENSURE SEAL LIPS DO NOT "FOLD OVER" DURING ASSEMBLY

PARTS LIST				PARTS LIST			
ITEM	PART NUMBER	DESCRIPTION	QTY	ITEM	PART NUMBER	DESCRIPTION	QTY
1	384-50-02-000	TAPERED HUB FAN ASSY - 540 RPM CHT	1	2.7	384-27-02-534	REIN. RING-1000 RPM COVER PLATE	1
1.1	364-72-00-422	FAN BLADE GUSSET	4	3	384-50-01-647	TAPERED HUB LOCKING PLATE	1
1.2	384-33-03-417	FAN BACK PLATE	1	4	384-50-01-648	TAPERED SHAFT CAP NUT	1
1.3	384-33-03-419	CHT 540 RPM FAN BLADE	4	5	R23444	O-RING #226 - 2.25" OD x 2" ID	1
1.4	384-50-02-639	TAPERED IMPELLER HUB	1	6	R23441	GREASE SEAL HM21 - 2.750" x 3.751" x .25"	2
1.5	R23443	HARDENED SEAL COLLAR - 2.75" OD	1	7	R07638	1/2-13 UNC x 1.5 HEX BOLT GR.5	4
2	384-50-03-000	COVER PLATE ASSY - TAPERED SHAFT	1	8	R07805	1/2 LOCK WASHER - ZINC	4
2.1	384-20-03-295	OUTER RING	1	9	R23506	M+S HYD MOTOR-MLHT160 TAPERED SHAFT-26 GPM	1
2.2	384-20-03-296	INNER RING	1		R22590	M+S HYD MOTOR-MLHT200 TAPERED SHAFT-33 GPM	1
2.3	384-20-00-301	RUBBER SEAL	1				
2.4	384-20-03-570	HATCH PIN SLEEVE	2				
2.5	384-50-03-642	MOTOR & BEARING BOX MOUNT	1	10	R23507	MACHINE KEY - 7/16" SQ x 1-1/4"	1
2.6	384-50-03-641	COVER PLATE-TAPERED SHAFT	1				

DRAIN PLUG KIT

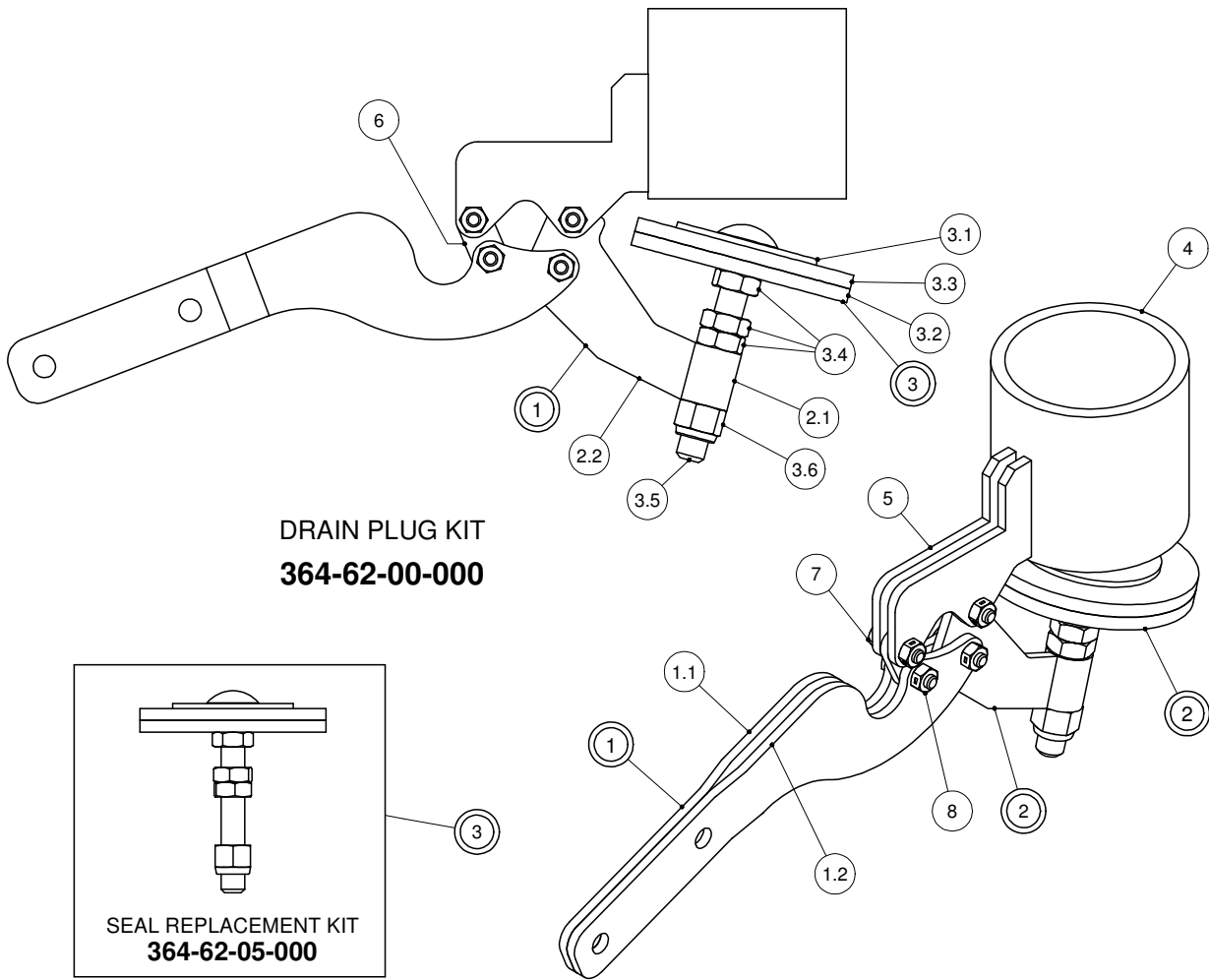

PARTS LIST

ITEM	PART NUMBER	DESCRIPTION	QTY
1	364-62-03-000	HANDLE ASSY	1
1.1	364-62-03-206	LH HANDLE	1
1.2	364-62-03-207	RH HANDLE	1
2	364-62-01-000	DRAIN PLUG SLEEVE ASSY	1
2.1	364-62-01-201	SLEEVE	1
2.2	364-62-01-200	SLEEVE LINKAGE	1
3	364-62-05-000	DRAIN PLUG REPLACEMENT KIT	1
3.1	364-62-04-370	PLUG WASHER	1
3.2	364-62-02-203	PLUG PLATE	1
3.3	R03071	DRAIN PLUG GASKET	1
3.4	R08046	1/2-13 UNC HEX JAM NUT - ZINC	3
3.5	R07748	1/2-13 UNC x 4 FULL THREAD CARRIAGE BOLT Gr.5	1
3.6	R08219	1/2-13 UNC NYLOCK NUT - ZINC	1
4	364-01-03-110	DRAIN PIPE	1
5	364-62-00-199	PLUG HOUSING BRKT	2
6	364-62-00-205	SHORT LINKAGE	1
7	R07176	1/4-20 UNC x 0.875 SHOULDER HEX BOLT GR.5	4
8	R08048	1/4-20 UNC 2-WAY LOCK NUT - ZINC	4

TAIL LIGHT KIT

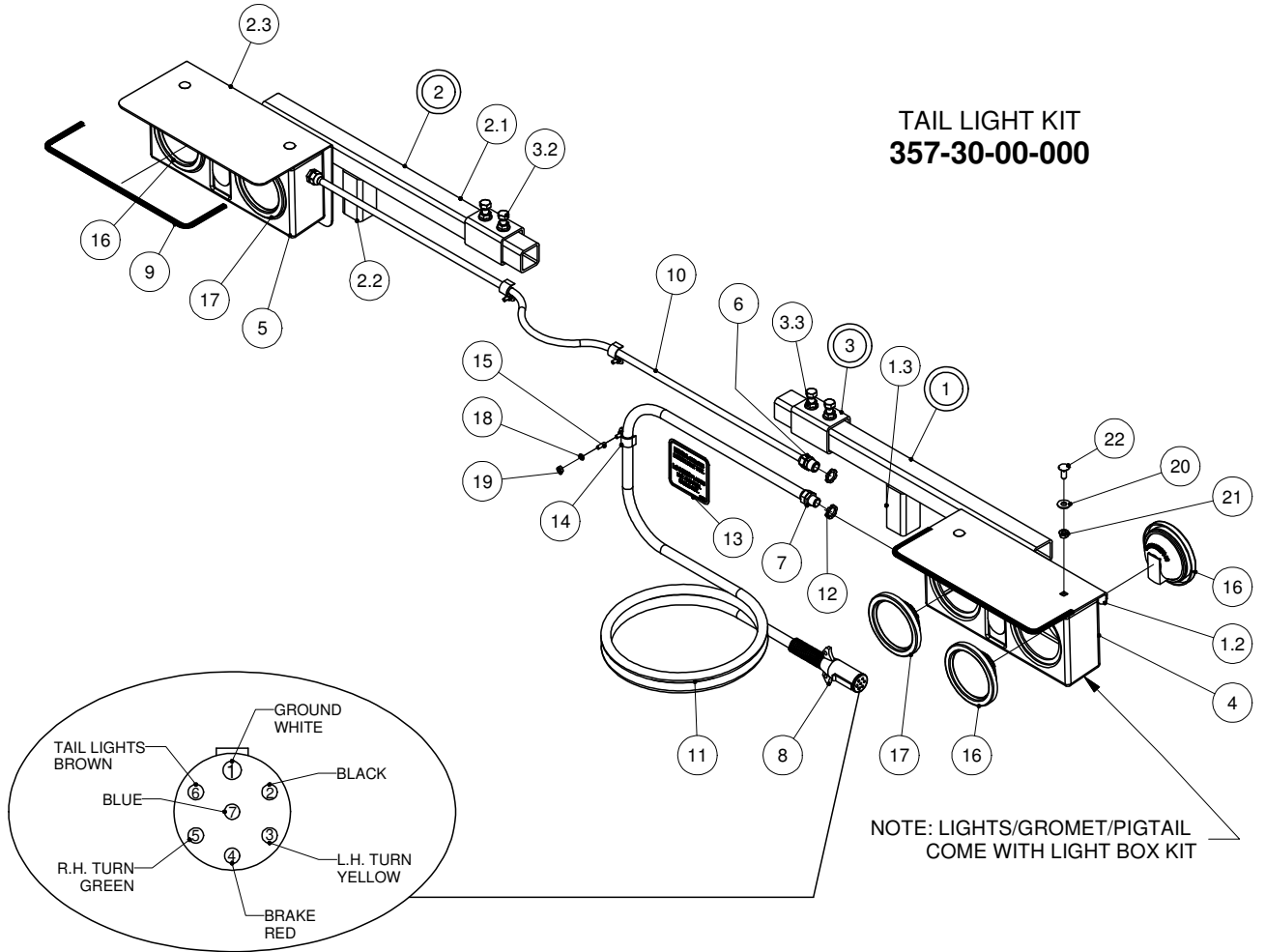

**TAIL LIGHT KIT
357-30-00-000**

NOTE: LIGHTS/GROMMET/PIGTAIL
COME WITH LIGHT BOX KIT

WIRING DIAGRAM
FOR 7 POLE CONNECTOR

PARTS LIST				PARTS LIST			
ITEM	PART NUMBER	DESCRIPTION	QTY	ITEM	PART NUMBER	DESCRIPTION	QTY
1	357-30-01-000	RH LIGHT BAR ASSY	1	8	R10095	7 POLE CONNECTOR w/ STRAIN RELIEF	1
1.1	357-30-01-171	LIGHT BAR	1				
1.2	357-30-01-172	RH LITE BOLT PLATE	1	9	357-30-00-311	SAFETY EDGING	2
1.3	357-30-01-173	STUB BAR	1	10	R04046	4-WIRE TRAILER CABLE - APPROX. 4M	1
2	357-30-02-000	LH LIGHT BAR ASSY	1	11	R04235	14/6 TRAILER CABLE - APPROX. 10.5M	1
2.1	357-30-01-171	LIGHT BAR	1	12	R10345	1/2" ELECTRICAL BOX LOCK NUT	3
2.2	357-30-01-173	STUB BAR	1	13	R09808	CABLE - LIGHT BOX DECAL	1
2.3	357-30-02-245	LH LITE BOLT PLATE	1	14	R21104	HYD. HOSE CLIPS	11
3	357-30-03-000	MOUNT BRKT ASSY	2	15	R08329	1/4-20 UNC x 3/4" WELD STUD	12
3.1	357-30-03-174	MOUNT BRKT	1	16	R10588	4" YELLOW LED LIGHT KIT	4
3.2	R07674	1/2-13 UNC x 1.25 HEX BOLT GR.5	2	17	R10358	4" RED LED LIGHT KIT	2
3.3	R07795	1/2-13 UNC FLANGE NUT - ZINC	2	18	R07801	1/4 LOCK WASHER - ZINC	11
4	R10349	RH LAMP BOX W/NO LIGHTS	1	19	R07781	1/4-20 UNC HEX NUT - ZINC	11
5	R10348	LH LAMP BOX W/ NO LIGHTS	1	20	R07823	3/8 FLAT WASHER STD - ZINC	4
6	R10193	1/2" NYLON TITE CONNECTOR	2	21	R07794	3/8-16 UNC FLANGE NUT - ZINC	4
7	R10357	3/4" NYLON TITE CONNECTOR	1	22	R07721	3/8-16 UNC x 1 CARRIAGE BOLT Gr.5	4

SIGHT GAUGE KIT

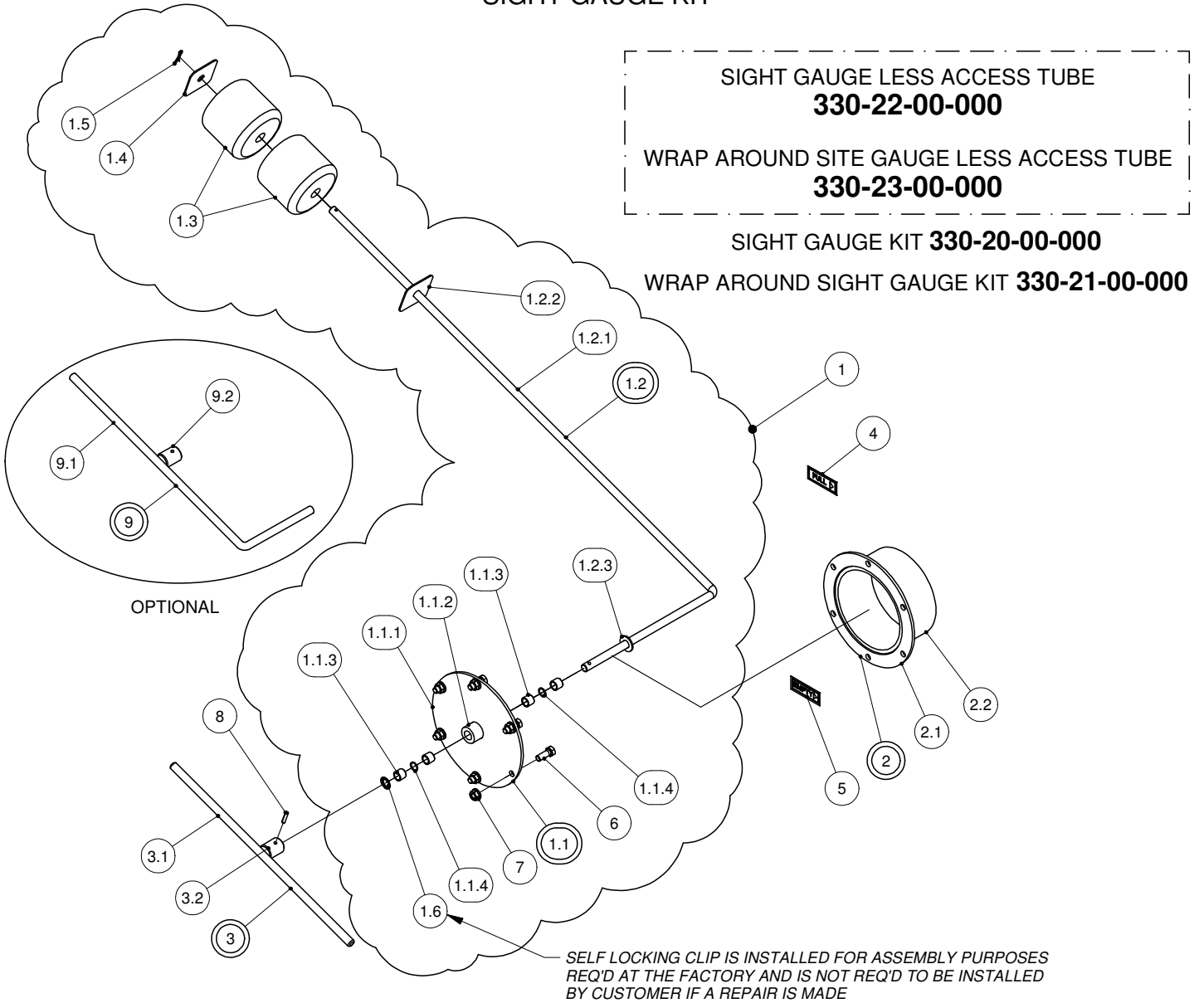

PARTS LIST				PARTS LIST			
ITEM	PART NUMBER	DESCRIPTION	QTY	ITEM	PART NUMBER	DESCRIPTION	QTY
1	330-22-01-000	SIGHT GAUGE w/o INDICATOR	1	2	330-20-03-000	ACCESS TUBE ASSY	1
1.1	330-20-04-000	COVER PLATE ASSY	1	2.1	330-20-03-560	ACCESS TUBE FLANGE	1
1.1.1	330-20-00-557	COVER PLATE	1	2.2	330-20-03-556	ACCESS TUBE	1
1.1.2	330-20-04-562	BUSHING HOLDER	1	3	330-20-02-000	INDICATOR ARM ASSY	1
1.1.3	R21173	1/2 x 5/8 x 1/2" BRONZE BUSHING	4	3.1	330-20-02-554	INDICATOR ARM	1
1.1.4	R20865	O-RING #11-014	2	3.2	330-20-02-553	INDICATOR ARM HUB	1
1.2	330-20-01-000	FLOAT ARM ASSY	1	4	R09529	"FULL" DECAL	1
1.2.1	330-20-01-551	FLOAT ARM	1	5	R09530	"EMPTY" DECAL	1
1.2.2	330-20-01-552	FLOAT STRAPS	1	6	R07619	3/8-16 UNC x 1 HEX BOLT GR.5	6
1.2.3	R08222	1/2 FLAT WASHER SAE - SS	1	7	R07794	3/8-16 UNC FLANGE NUT - ZINC	6
1.3	R09524	FLOAT	2	8	R08241	3/16 x 1 ROLL PIN - SS	1
1.4	330-20-01-552	FLOAT STRAPS	1	9	330-21-01-000	WRAP AROUND SITE ARM ASSY	1
1.5	R08021	1/8 x 1 S.S. COTTER PIN	1	9.1	330-19-46-546	WRAP AROUND SITE ARM	1
1.6	R08514	1/2" EXT. RETAINING RING	1	9.2	330-20-02-553	INDICATOR ARM HUB	1

SLIM LINE LADDER KIT

SLIM LINE LADDER KIT
394-07-00-000

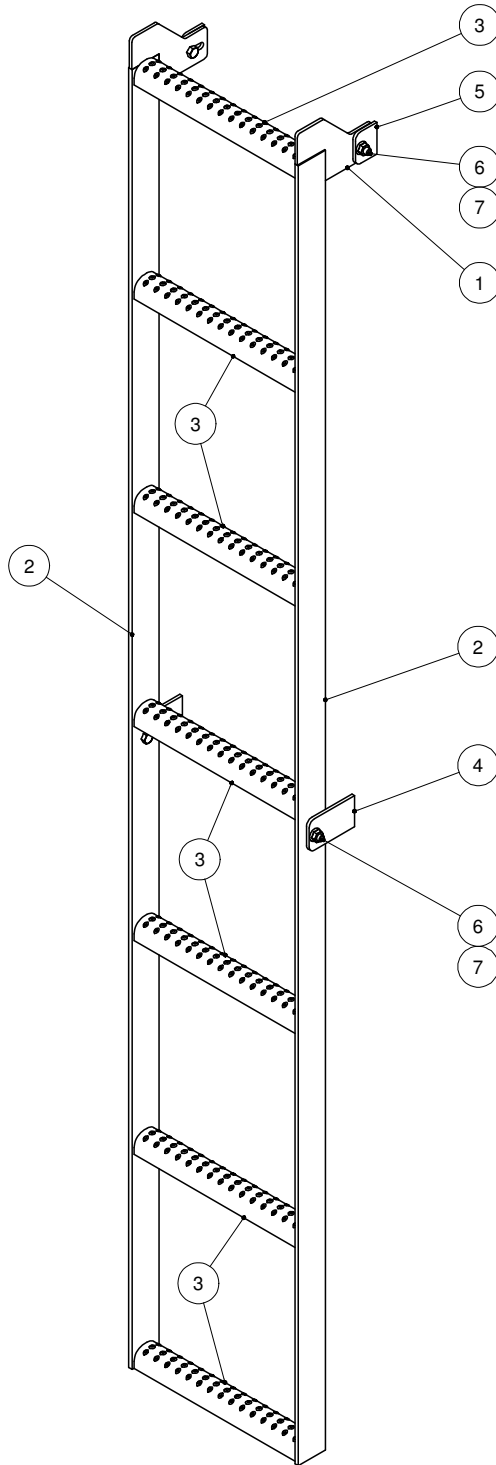

PARTS LIST

ITEM	PART NUMBER	DESCRIPTION	QTY
1	364-95-00-326	LADDER LUG	2
2	394-07-00-057	LADDER SIDE	2
3	364-95-00-324	LADDER RUNG	7
4	364-00-00-414	TANK LUG	2
5	364-95-00-327	UPPER TANK LUG	2
6	R07619	3/8-16 UNC x 1 HEX BOLT GR.5	4
7	R07794	3/8-16 UNC FLANGE NUT - ZINC	4

LOWER DISCHARGE PIPE KIT

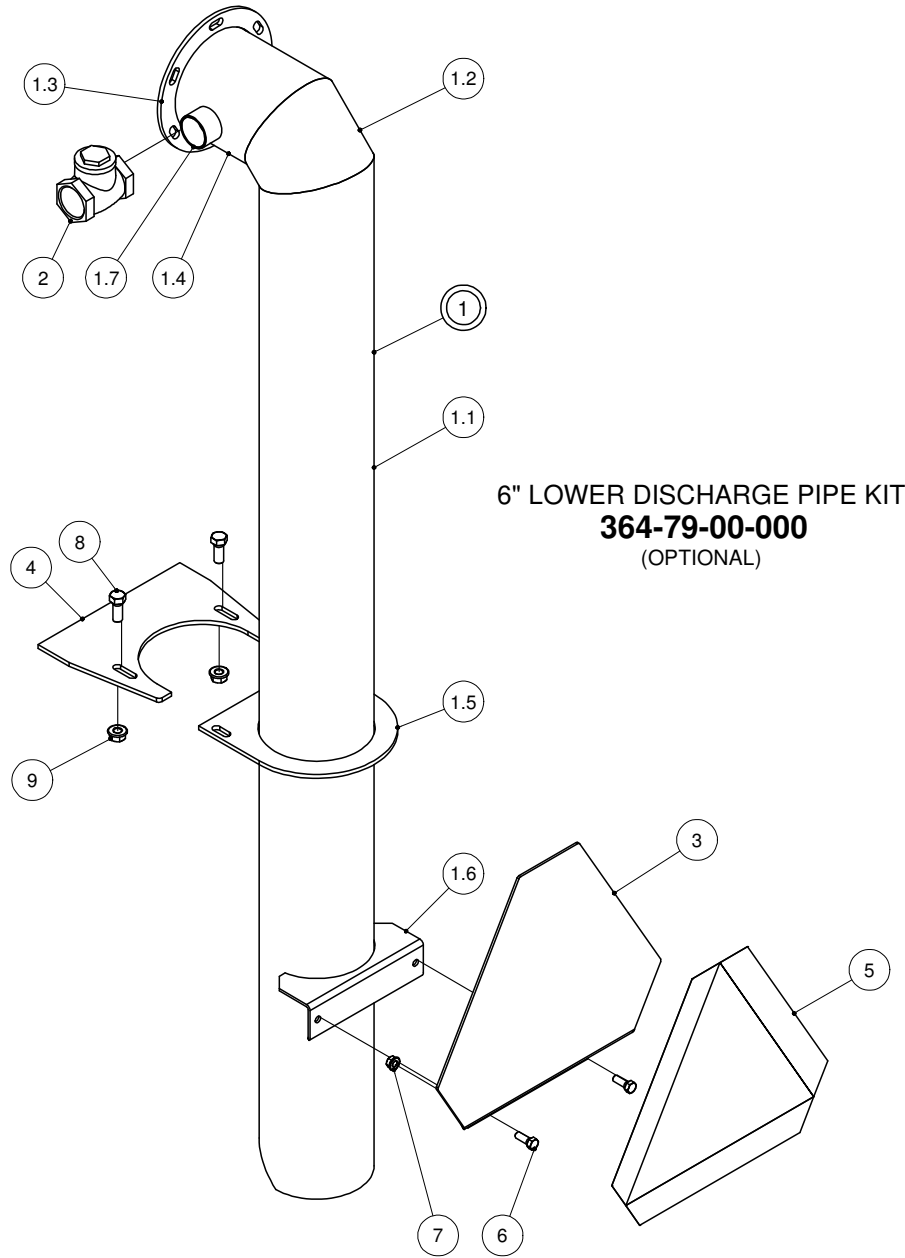

6" LOWER DISCHARGE PIPE KIT
364-79-00-000
(OPTIONAL)

PARTS LIST				PARTS LIST			
ITEM	PART NUMBER	DESCRIPTION	QTY	ITEM	PART NUMBER	DESCRIPTION	QTY
1	364-79-01-000	6" DROP PIPE ASSY-15000 PROFILE TANK	1	2	R02490	1 1/2" CHECK VALVE	1
				3	200-00-00-132	S.M.V. SIGN HOLDER	1
1.1	364-79-01-295	LONG DROP PIPE	1	4	384-05-03-070	TANK BRKT	1
1.2	364-19-00-082	DISCHARGE PIPE CORNER PC	1	5	R09501	SLOW MOVING VEHICLE DECAL	1
1.3	364-19-00-087	DISCHARGE PIPE FLANGE	1	6	R07619	3/8-16 UNC x 1 HEX BOLT GR.5	2
1.4	364-79-01-296	SHORT HORIZONTAL PIPE	1	7	R07794	3/8-16 UNC FLANGE NUT - ZINC	2
1.5	384-05-02-069	TUBE ATTACHMENT BRKT	1	8	R07674	1/2-13 UNC x 1.25 HEX BOLT GR.5	2
1.6	308-77-00-226	S.M.V. SIGN HOLDER	1	9	R07795	1/2-13 UNC FLANGE NUT - ZINC	2
1.7	R02127	1 1/2 CLOSE NIPPLE	1				

6" AGITATION KIT

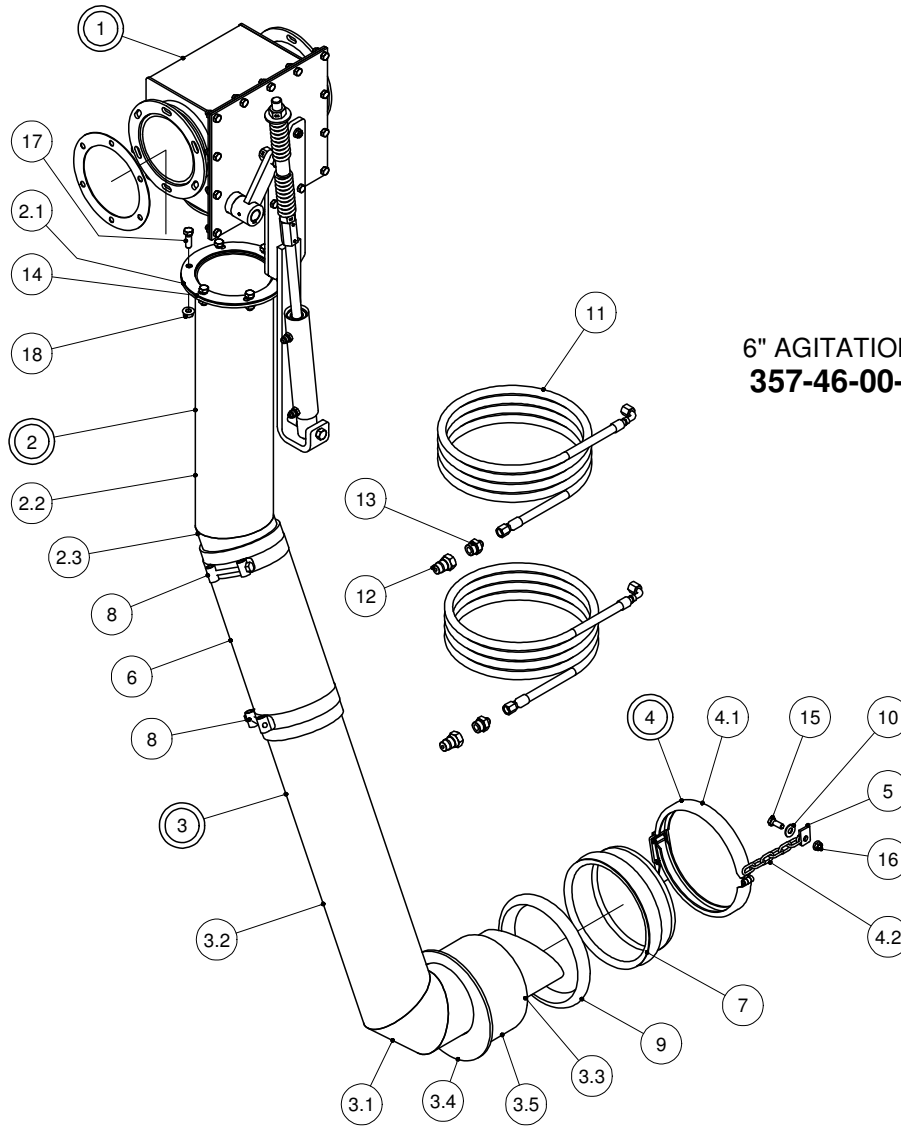

**6" AGITATION KIT
357-46-00-000**

PARTS LIST				PARTS LIST			
ITEM	PART NUMBER	DESCRIPTION	QTY	ITEM	PART NUMBER	DESCRIPTION	QTY
1	364-57-00-000	6" FLAPPER VALVE KIT-HORIZONTAL	1	6	357-46-00-222	FLEX HOSE	1
2	357-46-07-000	EXTENSION PIPE ASSY	1	7	395-08-00-051	8" DRAIN PIPE	1
2.1	364-19-00-087	DISCHARGE PIPE FLANGE	1	8	R02482	6" HOSE CLAMP	2
2.2	357-46-07-354	EXTENSION PIPE	1	9	R02863	8" CL GASKET	1
2.3	357-46-07-355	EXTENSION PIPE	1	10	R07823	3/8 FLAT WASHER STD - ZINC	1
3	357-46-08-000	AGITATOR PIPE ASSY	1	11	357-46-09-000	HYD HOSE ASSY-TRACTOR TO	2
3.1	1521662-PART-16	DISCHARGE PIPE CORNER PC	1		COILED	INSIDE AGITATION	
3.2	357-46-08-356	AGITATOR PIPE	1	12	R23182	MALE PIONEER TIP-ORB-10	2
3.3	357-46-08-357	AGITATOR PIPE BOTTOM PC	1	13	R23094	ORB-10 x 3/8" JIC M ADAPTOR	2
3.4	357-46-08-358	ADAPTOR FLANGE	1	14	R03068	6" DISCHARGE PIPE GASKET	2
3.5	395-08-04-052	DRAIN PLUG	1	15	R07619	3/8-16 UNC x 1 HEX BOLT GR.5	1
4	244-09-00-000	8" CLAMP & CHAIN ASSY	1	16	R07794	3/8-16 UNC FLANGE NUT - ZINC	1
4.1	R02488	8" RINGLOCK CLAMP	1	17	R07671	7/16-14 UNC x 1.25 HEX BOLT GR.5	6
4.2	250-97-00-297	CLAMP CHAIN	1	18	R07879	7/16-14 UNC FLANGE NUT - ZINC	6
5	250-96-00-298	CHAIN LUG	1				

8" AGITATION KIT

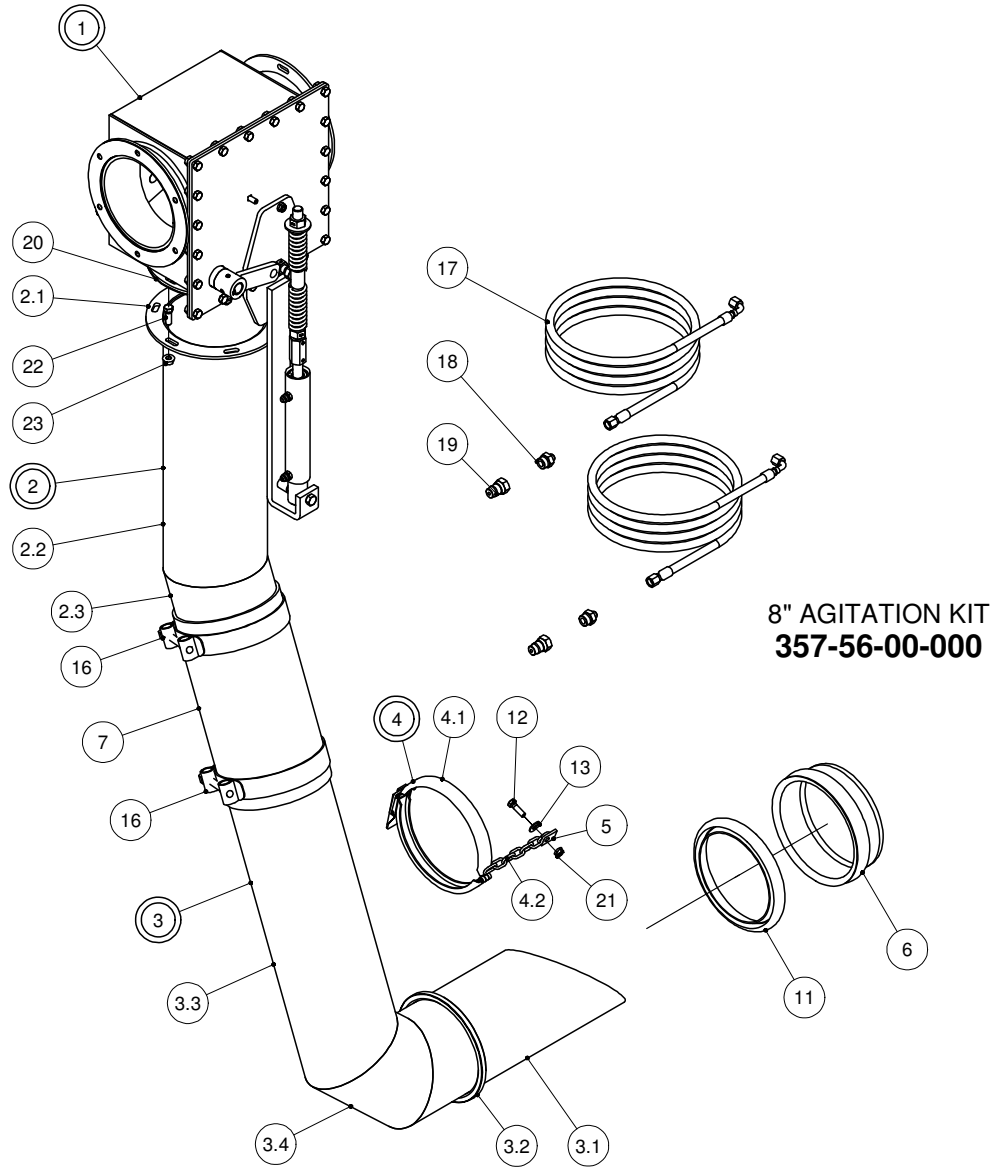

PARTS LIST				PARTS LIST			
ITEM	PART NUMBER	DESCRIPTION	QTY	ITEM	PART NUMBER	DESCRIPTION	QTY
1	386-13-00-000	8" FLAPPER BOX KIT W/ HYD CYL.	1	6	395-08-00-051	8" DRAIN PIPE	1
2	357-56-07-000	FLANGE EXTENSION ASSY	1	7	357-56-00-279	8" FLEX HOSE	1
2.1	358-92-02-306	8" DISCHARGE FLANGE	1	11	R02863	8" CL GASKET	1
2.2	357-56-07-360	EXTENSION PIPE	1	12	R07675	3/8-16 UNC x 1.25 HEX BOLT GR.5	1
2.3	357-56-07-361	SHORT EXTENSION PIPE	1	13	R07823	3/8 FLAT WASHER STD - ZINC	1
3	357-56-08-000	8" AGITATOR PIPE ASSY	1	16	R02484	8" SUCTION HOSE CLAMP	2
3.1	357-56-02-281	AGITATOR BASE PC	1	17	357-46-09-000	HYD HOSE ASSY-TRACTOR TO INSIDE AGITATION	2
3.2	244-08-00-307	CLAMP RING	1	18	R23094	ORB-10 x 3/8" JIC M ADAPTOR	2
3.3	357-56-08-362	AGITATOR PIPE	1	19	R23182	MALE PIONEER TIP-ORB-10	2
3.4	386-05-09-140	DISCHARGE MID PC	1	20	R03069	8" DISCHARGE PIPE GASKET	2
4	244-09-00-000	8" CLAMP & CHAIN ASSY	1	21	R07794	3/8-16 UNC FLANGE NUT - ZINC	1
4.1	R02488	8" RINGLOCK CLAMP	1	22	R07671	7/16-14 UNC x 1.25 HEX BOLT GR.5	6
4.2	250-97-00-297	CLAMP CHAIN	1	23	R07879	7/16-14 UNC FLANGE NUT - ZINC	6
5	250-96-00-298	CHAIN LUG	1				

6" FLAPPER BOX KIT

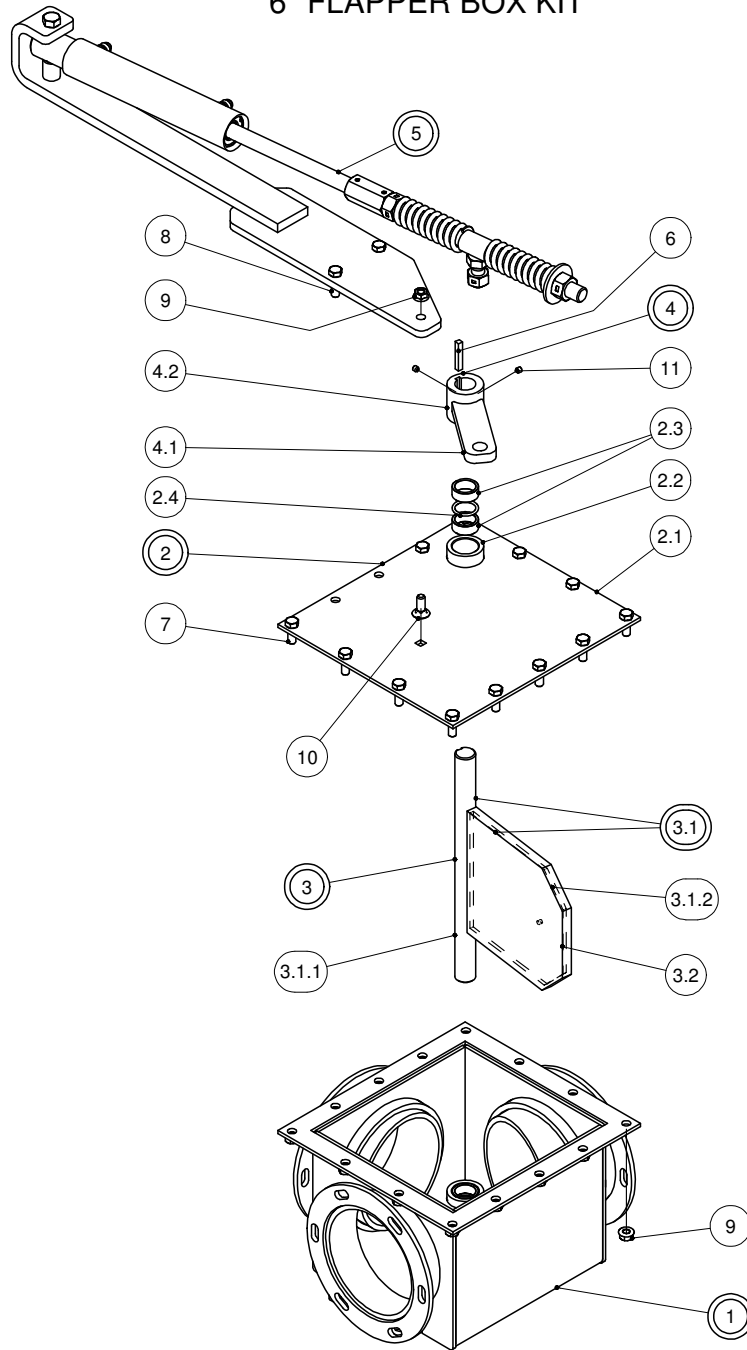

6" FLAPPER BOX KIT
364-57-00-000

PARTS LIST				PARTS LIST			
ITEM	PART NUMBER	DESCRIPTION	QTY	ITEM	PART NUMBER	DESCRIPTION	QTY
1	364-58-02-000	MAIN BODY ASSY	1	4	364-58-11-000	FLAPPER BRKT ASSY	1
2	364-58-03-000	COVER PLATE ASSY	1	4.1	364-58-11-321	BRKT ARM	1
2.1	364-58-03-267	COVER PLATE	1	4.2	364-58-11-322	ARM BRKT SLEEVE	1
2.2	364-58-02-266	BUSHING SLEEVE	1	5	364-58-17-000	6" CYLINDER & BRKT KIT-HORIZONTAL	1
2.3	R20266	1 1/4 OD x 1 ID x 1/2 LONG BUSHING	2			STYLE	
2.4	R20859	O RING 1 x 1 1/4 x 1/8"	1	6	364-58-08-323	KEY	1
3	364-58-01-000	FLAPPER ASSY COMPLETE w/ URETHANE	1	7	R07619	3/8-16 UNC x 1 HEX BOLT GR.5	12
3.1	364-58-14-000	FLAPPER ASSY	1	8	R07675	3/8-16 UNC x 1.25 HEX BOLT GR.5	2
3.1.1	364-58-01-262	FLAPPER SHAFT	1	9	R07794	3/8-16 UNC FLANGE NUT - ZINC	10
3.1.2	364-58-01-261	FLAPPER	1	10	R07721	3/8-16 UNC x 1 CARRIAGE BOLT Gr.5	1
3.2	R20216	URETHANE	1	11	R07929	1/4-28 UNF x 0.25 SET SCREW - ZINC	2

8" FLAPPER BOX KIT

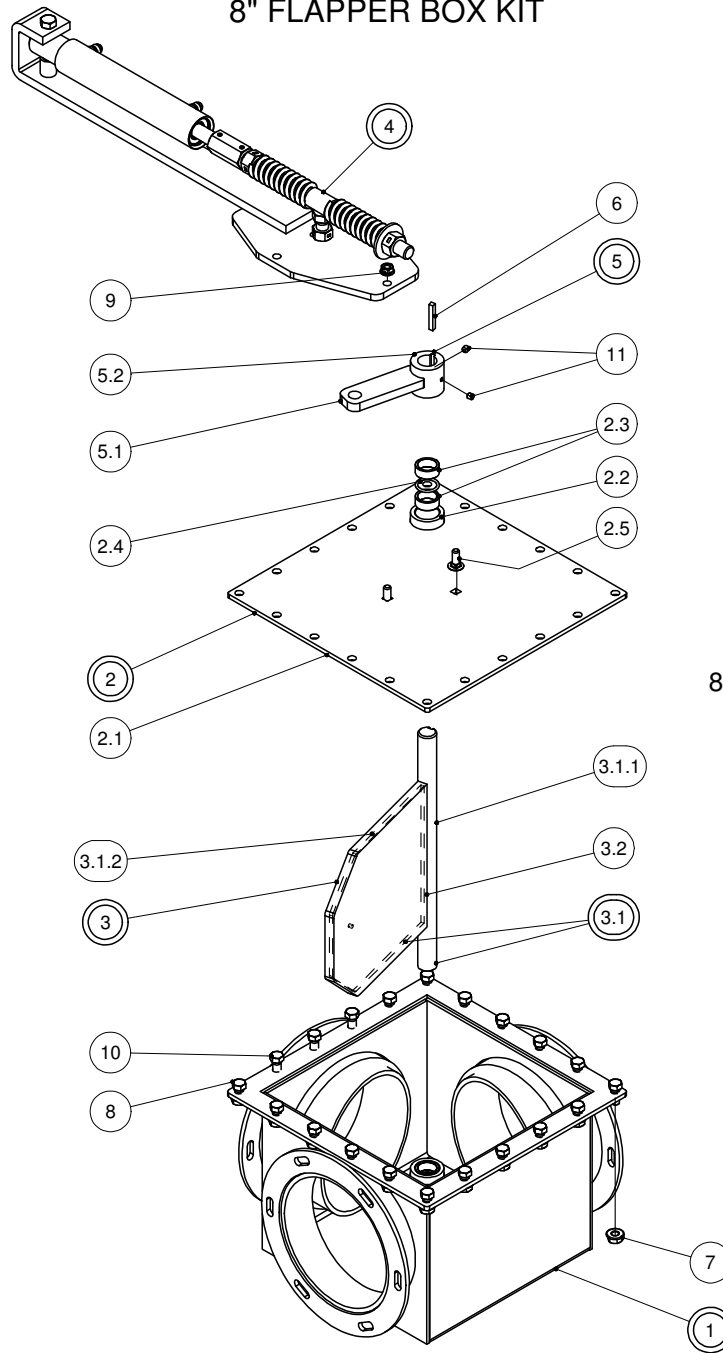

**8" FLAPPER BOX KIT
386-13-00-000**

PARTS LIST				PARTS LIST			
ITEM	PART NUMBER	DESCRIPTION	QTY	ITEM	PART NUMBER	DESCRIPTION	QTY
1	386-07-01-000	8" FLAPPER BOX ASSY	1	3.2	R20225	URETHANE	1
2	386-07-05-000	COVER PLATE ASSY	1	4	386-13-01-000	HORIZONTAL CYLINDER & BRKT KIT-8"	1
2.1	386-07-05-114	COVER PLATE	1	5	364-58-11-000	FLAPPER BRKT ASSY	1
2.2	364-58-02-266	BUSHING SLEEVE	1	5.1	364-58-11-321	BRKT ARM	1
2.3	R20266	1 1/4 OD x 1 ID x 1/2 LONG BUSHING	2	5.2	364-58-11-322	ARM BRKT SLEEVE	1
2.4	R20859	O RING 1 x 1 1/4 x 1/8"	1	6	364-58-08-323	KEY	1
2.5	R07721	3/8-16 UNC x 1 CARRIAGE BOLT Gr.5	2	7	R07879	7/16-14 UNC FLANGE NUT - ZINC	17
3	386-07-06-000	FLAPPER ASSY w/ URETHENE	1	8	R07628	7/16-14 UNC x 1 HEX BOLT GR.5	17
3.1	386-07-04-000	FLAPPER ASSY	1	9	R07794	3/8-16 UNC FLANGE NUT - ZINC	1
3.1.1	386-07-04-113	FLAPPER SHAFT	1	10	R07671	7/16-14 UNC x 1.25 HEX BOLT GR.5	3
3.1.2	386-07-04-112	FLAPPER	1	11	R07906	5/16-18 UNC x 0.31 SET SCREW - ZINC	2

6" CYLINDER & BRKT KIT

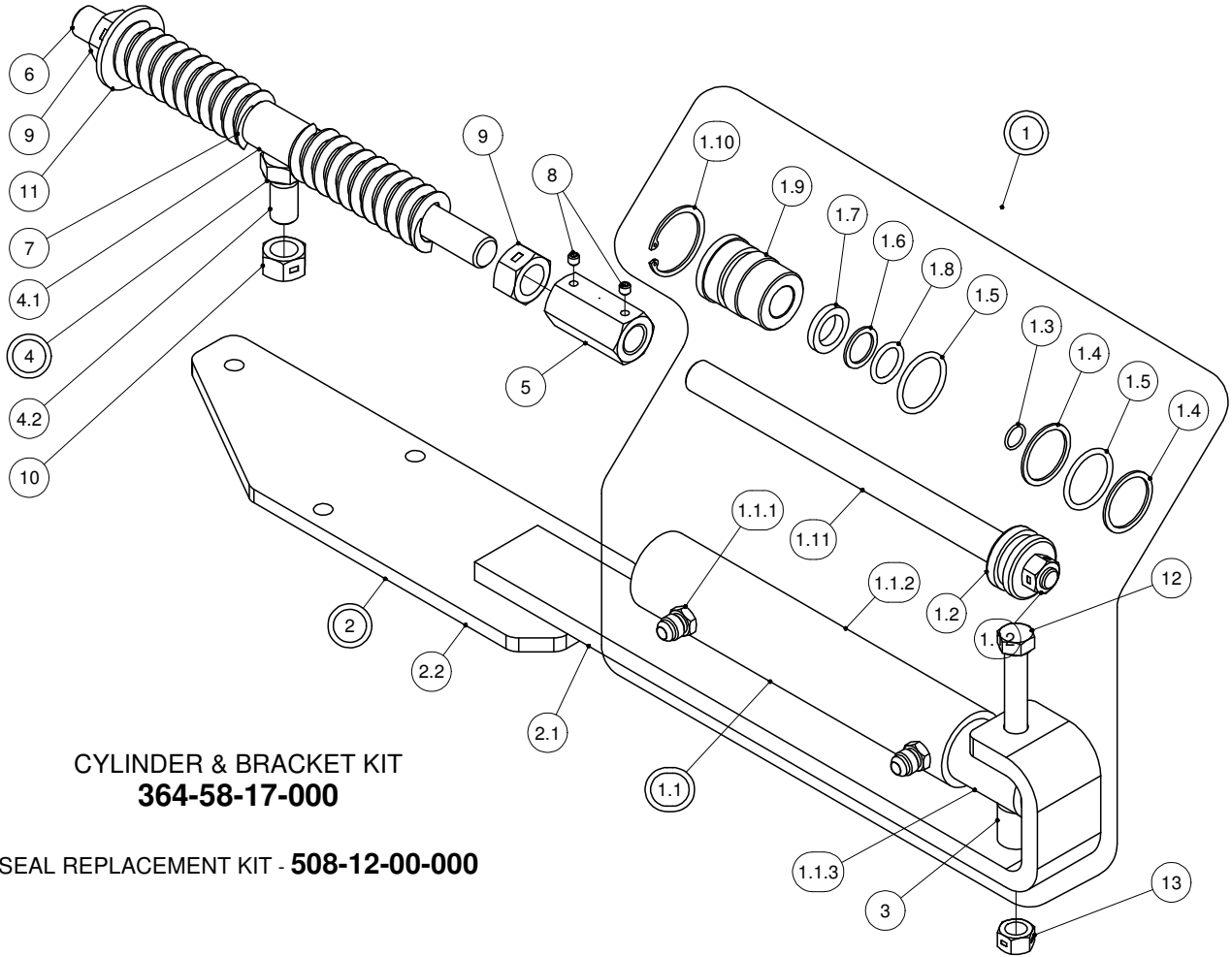

**CYLINDER & BRACKET KIT
364-58-17-000**

SEAL REPLACEMENT KIT - 508-12-00-000

PARTS LIST				PARTS LIST			
ITEM	PART NUMBER	DESCRIPTION	QTY	ITEM	PART NUMBER	DESCRIPTION	QTY
1	508-11-00-000	DEFLECTOR CYL COMPLETE - JIC	1	2	364-58-16-000	CYLINDER BRKT ASSY	1
1.1	508-11-01-000	DEFLECTOR CYL TUBE ASSY - JIC	1	2.1	364-58-09-317	CYLINDER BRKT	1
1.1.1	R23151	3/8" M. JIC WELD FITTING	2	2.2	364-58-16-508	CYLINDER BRKTBOLT PLATE	1
1.1.2	508-11-01-038	DEFLECTOR CYL TUBE - JIC	1	3	364-58-08-318	SPACER PIPE	1
1.1.3	508-11-01-042	DEFLECTOR CYL END CAP - JIC	1	4	364-58-10-000	PIVOT AND SLEEVE ASSY	1
1.2	340-36-00-435	CYLINDER PLUNGER	1	4.1	364-58-10-320	PIVOT SLEEVE	1
1.3	R20865	O-RING #11-014	1	4.2	R07673	5/8-11 UNC x 1.25 HEX BOLT GR.5	1
1.4	R20867	BACKUP RING #8-218	2	5	364-58-08-257	3/4" COUPLER	1
1.5	R20866	O-RING #11-218	2	6	364-58-08-319	EXTENSION SHAFT	1
1.6	R20862	3/4" BACKUP #210	1	7	R08033	HP 68 x 3/4 x 4" SPRING	2
1.7	R20774	3/4" HYTREL ROD WIPER 52-750	1	8	R07910	1/4-20 UNC x 0.25 SET SCREW - ZINC	2
1.8	R20771	O-RING #11-210	1	9	R07881	3/4-10 UNC 2-WAY LOCK NUT - ZINC	2
1.9	508-09-00-039	WIPER BLOCK - JIC	1	10	R07887	5/8-11 UNC 2-WAY LOCK NUT - ZINC	1
1.10	R08198	1 9/16" INTERNAL SNAP RING	1	11	R07827	3/4 FLAT WASHER STD - ZINC	1
1.11	275-15-00-122	HYDRAULIC CYLINDER SHAFT	1	12	R07643	1/2-13 UNC x 4 HEX BOLT GR.5	1
1.12	R07885	1/2-13 UNC 2-WAY LOCK NUT - ZINC	1	13	R07885	1/2-13 UNC 2-WAY LOCK NUT - ZINC	1

8in CYLINDER & BRKT KIT

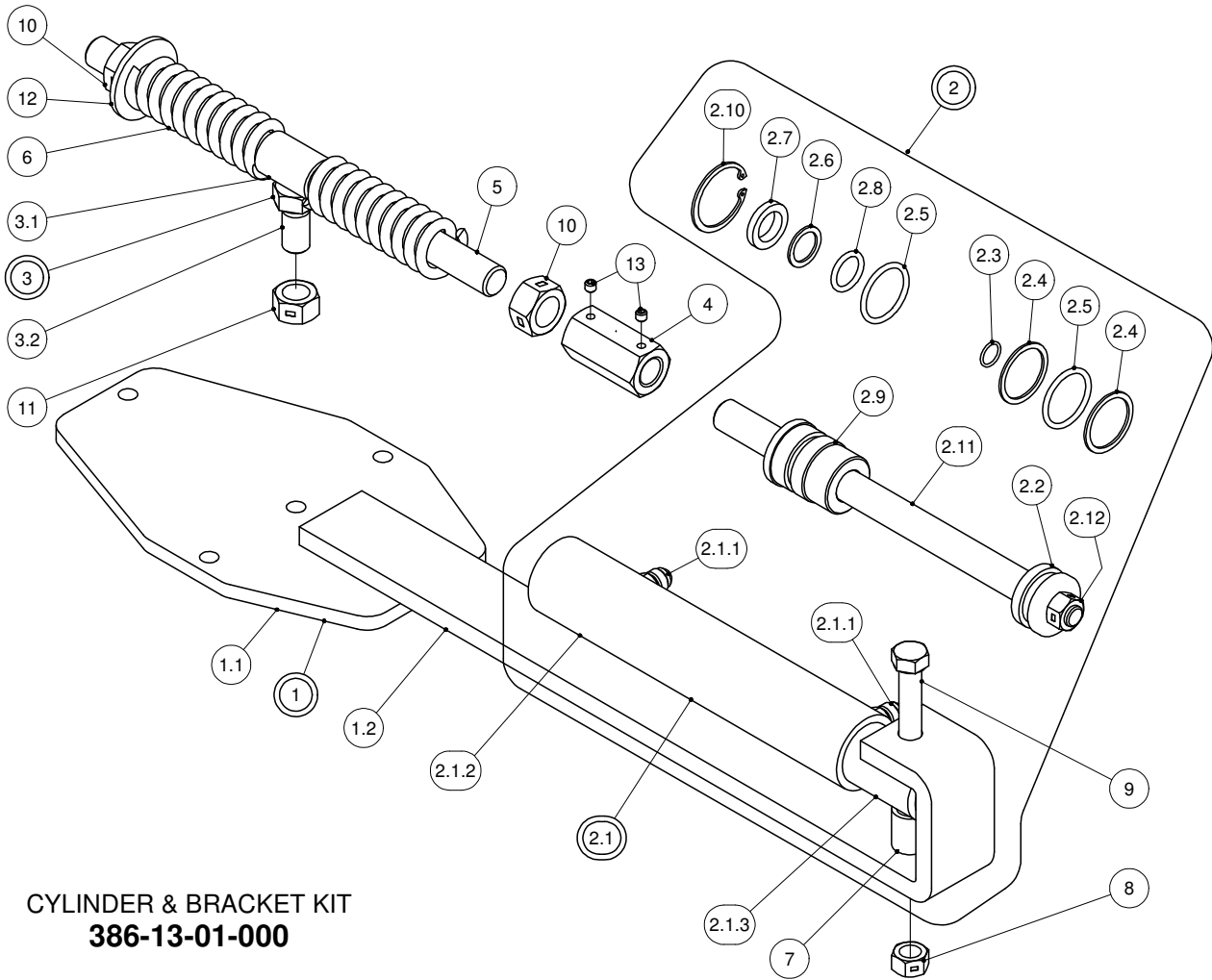

CYLINDER & BRACKET KIT 386-13-01-000

SEAL REPLACEMENT KIT - 508-12-00-000

PARTS LIST				PARTS LIST			
ITEM	PART NUMBER	DESCRIPTION	QTY	ITEM	PART NUMBER	DESCRIPTION	QTY
1	386-13-02-000	CYLINDER BRKT ASSY-8" VALVE	1	2.10	R08198	1 9/16" INTERNAL SNAP RING	1
1.1	386-13-02-307	CYLINDER BRKT BOLT PLATE-8"	1	2.11	275-15-00-122	HYDRAULIC CYLINDER SHAFT	1
1.2	386-13-02-342	CYLINDER BRKT (HOR CYLINDER)	1	2.12	R07885	1/2-13 UNC 2-WAY LOCK NUT - ZINC	1
2	508-11-00-000	DEFLECTOR CYL COMPLETE - JIC	1	3	364-58-10-000	PIVOT AND SLEEVE ASSY	1
2.1	508-11-01-000	DEFLECTOR CYL TUBE ASSY - JIC	1	3.1	364-58-10-320	PIVOT SLEEVE	1
2.1.1	R23151	3/8" M. JIC WELD FITTING	2	3.2	R07673	5/8-11 UNC x 1.25 HEX BOLT GR.5	1
2.1.2	508-11-01-038	DEFLECTOR CYL TUBE - JIC	1	4	364-58-08-257	3/4" COUPLER	1
2.1.3	508-11-01-042	DEFLECTOR CYL END CAP - JIC	1	5	364-58-08-319	EXTENSION SHAFT	1
2.2	340-36-00-435	CYLINDER PLUNGER	1	6	R08033	HP 68 x 3/4 x 4" SPRING	2
2.3	R20865	O-RING #11-014	1	7	364-58-08-318	SPACER PIPE	1
2.4	R20867	BACKUP RING #8-218	2	8	R07885	1/2-13 UNC 2-WAY LOCK NUT - ZINC	1
2.5	R20866	O-RING #11-218	2	9	R07643	1/2-13 UNC x 4 HEX BOLT GR.5	1
2.6	R20862	3/4" BACKUP #210	1	10	R07881	3/4-10 UNC 2-WAY LOCK NUT - ZINC	2
2.7	R20774	3/4" HYTREL ROD WIPER 52-750	1	11	R07887	5/8-11 UNC 2-WAY LOCK NUT - ZINC	1
2.8	R20771	O-RING #11-210	1	12	R07827	3/4 FLAT WASHER STD - ZINC	1
2.9	508-09-00-039	WIPER BLOCK - JIC	1	13	R07910	1/4-20 UNC x 0.25 SET SCREW - ZINC	2

CARLISLE 4x73 BRAKE KIT-25K HUBS

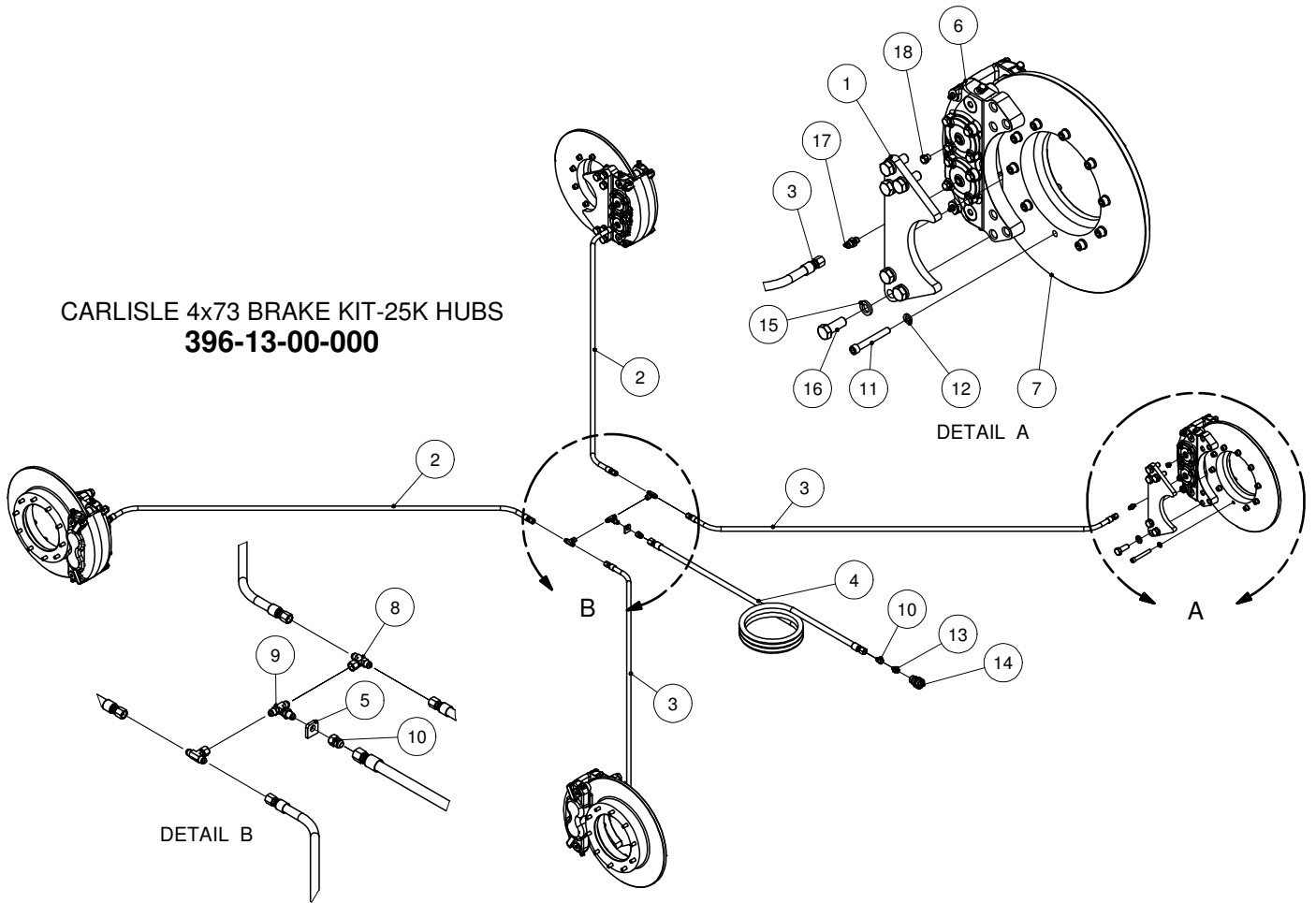

PARTS LIST			
ITEM	PART NUMBER	DESCRIPTION	QTY
1	396-13-00-171	CARLISLE 4x73 CALIPER MOUNT PLATE-25K	4
2	394-15-01-000	BRAKE HOSE ASSY 3/8" - REAR	2
3	394-15-02-000	BRAKE HOSE ASSY 3/8" - FRONT	2
4	394-15-03-000	MAIN BRAKE LINE ASSY-1/2"	1
5	394-15-00-110	BULKHEAD PLATE - 1 HOLE	1
6	R22658	CARLISLE 4x73 CALIPER	4
7	R22660	20" OD CAST BRAKE ROTOR-25K	4
8	R23120	3/8"M X 3/8"M X 3/8" SW F JIC TEE	2
9	R23222	3/8" JIC BULKHEAD TEE	1
10	R23077	3/8" JIC F. x 1/2" JIC M. BUSHING	2
11	R08417	1/2 x 3 3/4 UNF SHCS	40
12	R07805	1/2" LOCK WASHER	40
13	R23126	3/8" BSPP M. X 3/8" JIC M. ADAPTER	1
14	R23180	FASTER F. BRAKE COUPLING	1
15	R07807	3/4" LOCK WASHER	24
16	R07654	3/4 x 2 UNC HEX BOLT	24
17	R22149	ORB-5 x 3/8" JIC M. ADAPTER	4
18	R23326	ORB-5 SAE Hex Head Plug	4

BRAKE MODULATION KIT

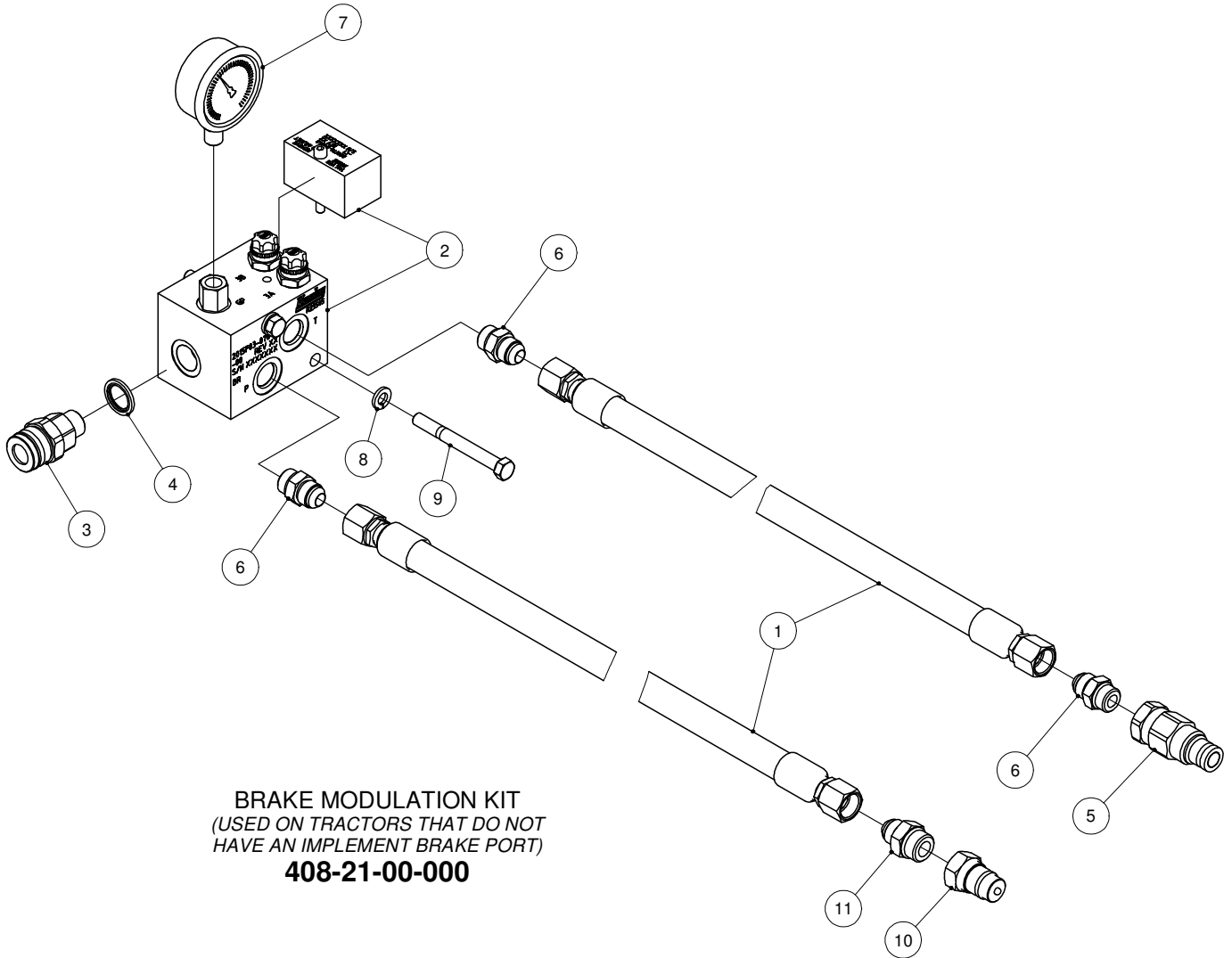

BRAKE MODULATION KIT
 (USED ON TRACTORS THAT DO NOT
 HAVE AN IMPLEMENT BRAKE PORT)
408-21-00-000

PARTS LIST			
ITEM	PART NUMBER	DESCRIPTION	QTY
1	408-21-01-000	HYD HOSE ASSY-MANIFOLD TO TRACTOR	2
2	R23505	BRAKE VALVE MANIFOLD-LYNCH	1
3	R23200	1/2" BSPP MALE FASTER COUPLING	1
4	R23148	1/2" BSPP BONDED SEAL	1
5	R23187	FASTER CASE DRAIN NIPPLE ORB-08	1
6	R23092	ORB-8 x 1/2" JIC M. ADAPTOR	3
7	R21251	2-1/2" SS PRESSURE GAUGE 3000 PSI	1
8	R07803	3/8 LOCK WASHER - ZINC	2
9	R07624	3/8-16 UNC x 3.5 HEX BOLT GR.5	2
10	R23182	MALE PIONEER TIP-ORB-10	1
11	R23095	ORB-10 x 1/2" JIC M ADAPTOR	1

TANK VENT KIT

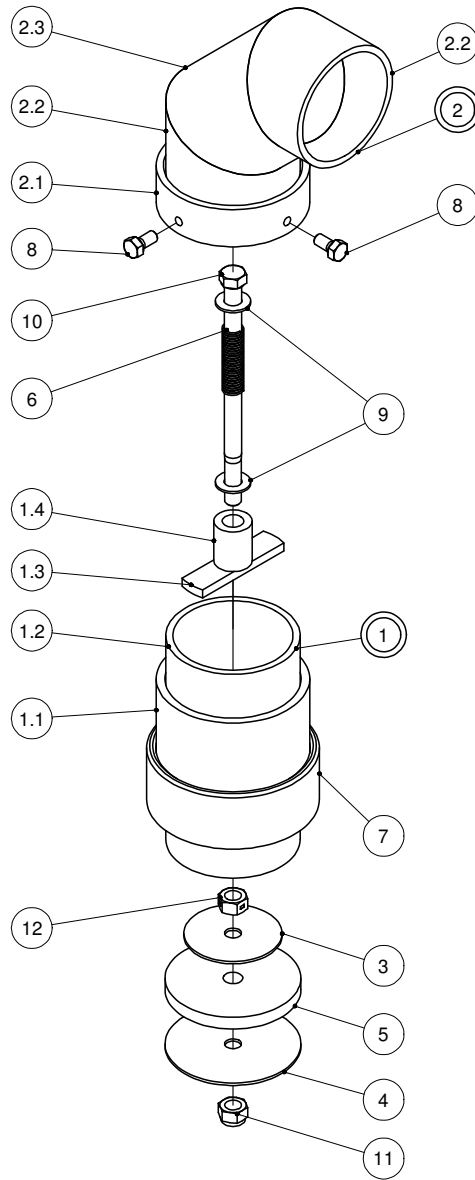

TANK VENT KIT
357-51-00-000
(OPTIONAL)

PARTS LIST				PARTS LIST			
ITEM	PART NUMBER	DESCRIPTION	QTY	ITEM	PART NUMBER	DESCRIPTION	QTY
1	357-51-01-000	VENT TUBE ASSY	1	4	357-51-00-258	LOWER STAINLESS STEEL WASHER	1
1.1	R02993	3 1/2" X 3" TOE PIPE NIPPLE	1	5	357-51-00-334	RUBBER PLUG	1
1.2	357-51-01-246	VENT TUBE	1	6	357-51-00-249	SPRING	1
1.3	357-51-01-247	VENT STRAP	1	7	R02969	3 1/2" HALF COUPLER	1
1.4	357-51-01-248	INNER SLIDE TUBE	1	8	R07690	5/16-18 UNC x 0.625 HEX BOLT GR.5	2
2	357-51-02-000	CAP ASSY	1	9	R08221	7/16 FLAT WASHER SAE - SS	2
2.1	357-51-02-251	SLEEVE	1	10	R07689	7/16-14 UNC x 7 HEX BOLT GR.5	1
2.2	357-51-02-252	ELBOW SECTION	2	11	R08178	7/16-14 UNC NYLOCK NUT - ZINC	1
2.3	357-51-02-253	ELBOW MIDDLE SECTION	1	12	R07891	7/16-14 UNC 2-WAY LOCK NUT - ZINC	1
3	357-51-00-250	STAINLESS STEEL WASHER	1				

SLIDE LID KIT

SLIDE LID KIT
357-45-00-000
(OPTIONAL)

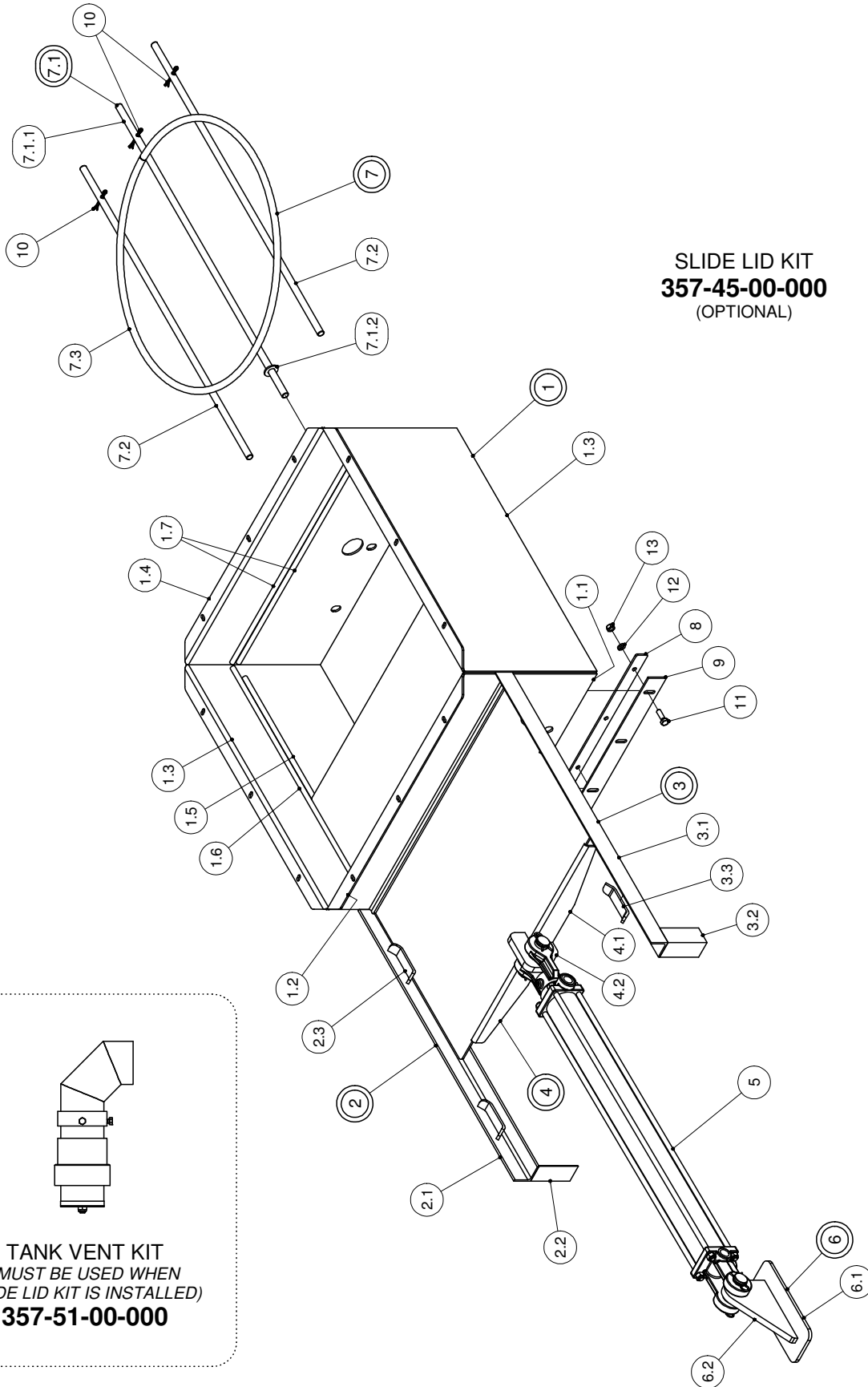

TANK VENT KIT
(MUST BE USED WHEN
SLIDE LID KIT IS INSTALLED)
357-51-00-000

SLIDE LID KIT

PARTS LIST			
ITEM	PART NUMBER	DESCRIPTION	QTY
1	357-45-01-000	24" SLIDE LID ASSY	1
1.1	357-45-01-204	SLIDE LID FRONT LOWER PANEL	1
1.2	357-45-01-205	SLIDE LID FRONT UPPER PANEL	1
1.3	357-45-01-202	24" SLIDE LID SIDE	2
1.4	357-45-01-203	SLIDE LID REAR PANEL	1
1.5	357-45-01-257	SIDE LOWER GUIDE BARS	2
1.6	357-45-01-206	SIDE UPPER GUIDE BARS	2
1.7	357-45-01-207	REAR GUIDE BAR	2
2	357-45-02-000	RH SLIDE RAIL ASSY	1
2.1	357-45-02-209	SLIDE RAIL	1
2.2	357-45-02-210	SLIDE RAIL LEG	1
2.3	357-45-02-208	LOWER GUIDE	2
3	357-45-04-000	LH SLIDE RAIL ASSY	1
3.1	357-45-02-209	SLIDE RAIL	1
3.2	357-45-02-210	SLIDE RAIL LEG	1
3.3	357-45-02-208	LOWER GUIDE	2
4	357-45-03-000	24" SLIDING LID ASSY	1
4.1	357-45-03-213	24" SLIDE LID	1
4.2	357-45-03-214	SLIDE LID LUG	1
5	R23274	20TH24 HYD CYL-ORB	1
	R21575	3.25" x 24" AIR CYLINDER	*
6	357-45-07-000	TANK LUG ASSY FOR HYD/AIR CYLINDER	1
6.1	368-54-02-425	CYLINDER BRKT BASE PLATE	1
6.2	357-45-07-254	TANK LUG FOR HYD/AIR CYLINDER	1
7	357-45-09-000	SAFETY GRATE ASSY	1
7.1	357-45-08-000	SAFETY BAR ASSY	1
7.1.1	357-45-08-274	SAFETY BAR	1
7.1.2	R08222	1/2 FLAT WASHER SAE - SS	1
7.2	357-45-08-274	SAFETY BAR	2
7.3	357-45-09-314	SAFETY RING	1
8	357-45-00-211	SLIDE LID RUBBER STRAP	1
9	357-45-00-212	RUBBER	1
10	R08207	5/32 x 1 1/2 COTTER PIN - SS	3
11	R07611	5/16-18 UNC x 1 HEX BOLT GR.5	5
12	R07802	5/16 LOCK WASHER - ZINC	5
13	R07782	5/16-18 UNC HEX NUT - ZINC	5

BUTTERFLY LID & SAFETY GRATE

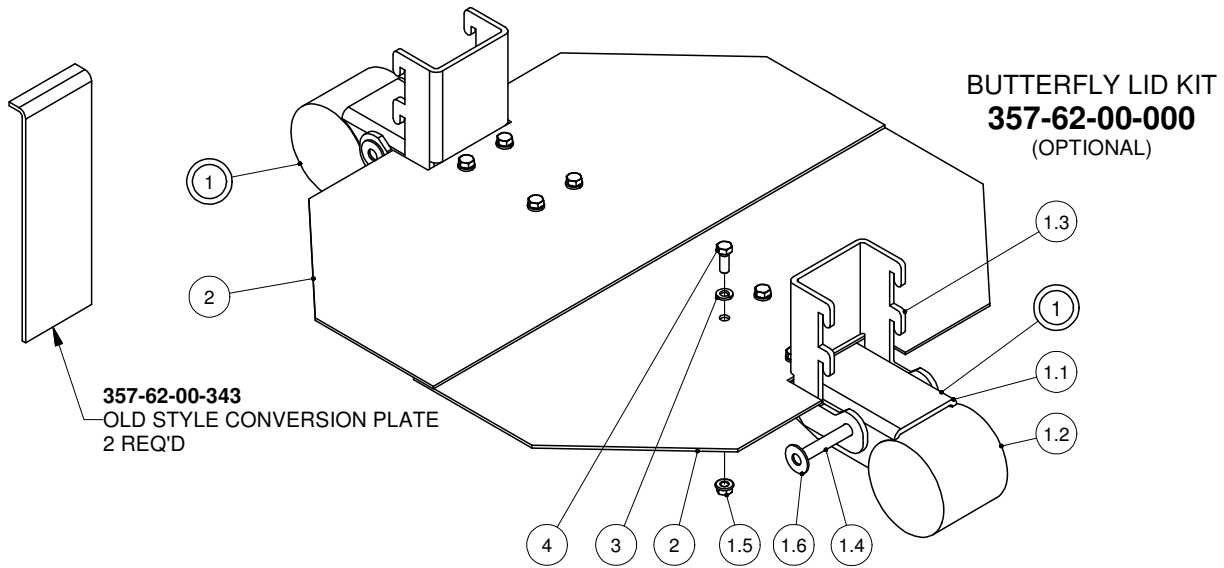

NOTE: WITH INSTALLATION OF A BUTTERFLY LID, A SAFETY GRATE MUST BE USED TO LOCK LID IN PLACE

PARTS LIST				PARTS LIST			
ITEM	PART NUMBER	DESCRIPTION	QTY	ITEM	PART NUMBER	DESCRIPTION	QTY
1	357-62-01-000	BUTTERFLY HINGE KIT	2	1.5	R07794	3/8-16 UNC FLANGE NUT - ZINC	4
1.1	357-62-01-316	U - CHANNEL HINGE	1	1.6	R07824	7/16 FLAT WASHER STD - ZINC	2
1.2	357-62-01-317	COUNTER WEIGHT	1	2	357-62-00-318	BUTTERFLY LID	2
1.3	357-62-01-319	DROP-IN HINGE	1	3	R08319	3/8 LOCK WASHER - SS	8
1.4	357-62-01-315	HINGE PIN	1	4	R07619	3/8-16 UNC x 1 HEX BOLT GR.5	8

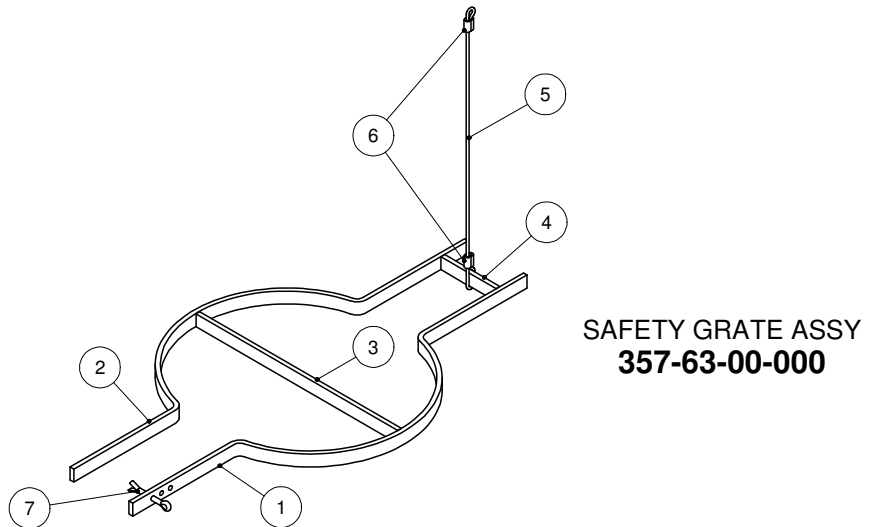

PARTS LIST			
ITEM	PART NUMBER	DESCRIPTION	QTY
1	357-63-00-320	SAFETY BAR w/ HOLE	1
2	357-63-00-332	SAFETY BAR	1
3	357-63-00-321	CROSS SAFETY BAR	1
4	357-63-00-322	STOP BAR	1
5	357-63-00-331	SAFETY CABLE	1
6	R08068	1/8" ALUMINUM CRIMP SLEEVES	2
7	R08016	1/4 x 2 COTTER PIN	1

FILL HOLE OPTIONS

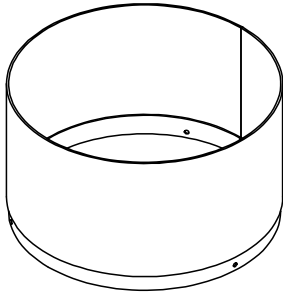

12" FILL HOLE EXTENSION
FOR Ø24" ROUND FILL HOLE
408-20-00-000

6" FILL HOLE EXTENSION
FOR Ø24" ROUND FILL HOLE
358-16-00-000

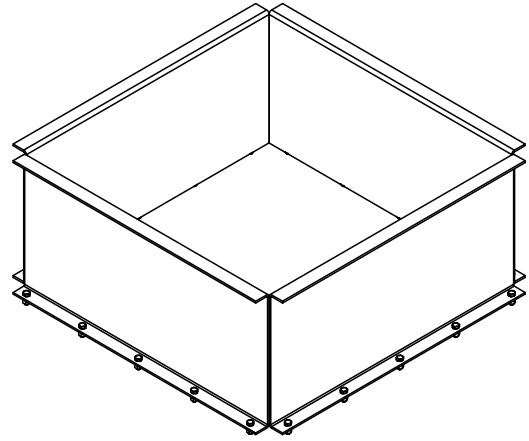

14" FILL HOLE EXTENSION
FOR 30" SQ LIP OUT FILL HOLE
356-15-00-000

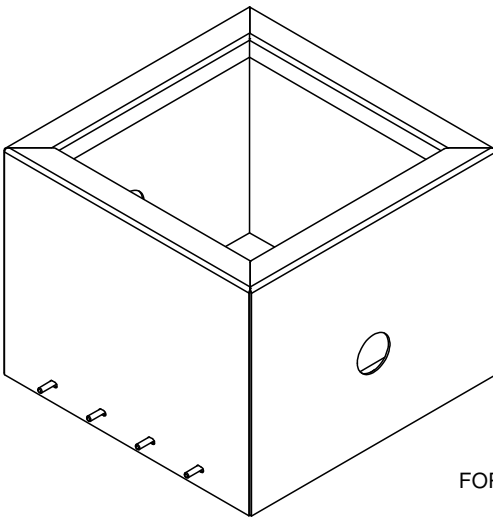

30" SQUARE FILL HOLE
"LIP IN"
384-29-00-000

SAFETY BAR ASSY
FOR 30" SQ FILL HOLES
384-28-00-000

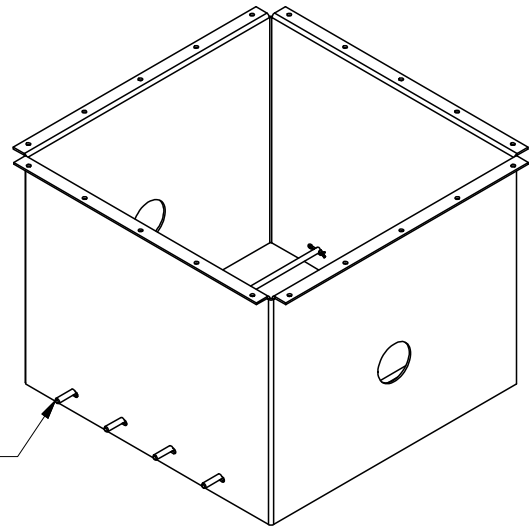

30" SQUARE FILL HOLE
"LIP OUT"
356-14-00-000

SPREADERS PTO - 2012

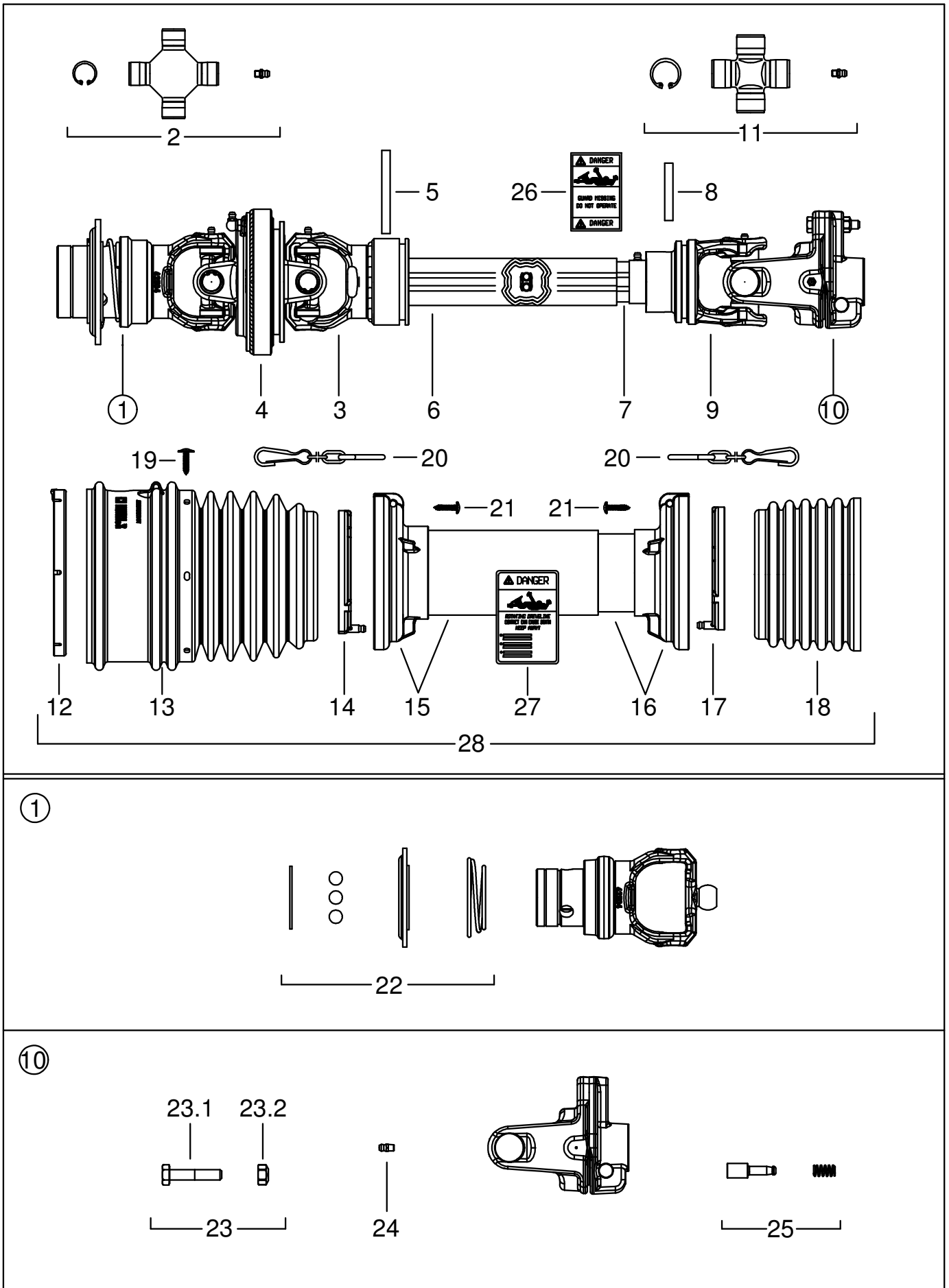

SPREADERS PTO - 2012

R21582 - 1 3/8" 6 TOOTH - 540 RPM

R21583 - 1 3/8" 21 TOOTH - 1000 RPM

R21584 - 1 3/4" 20 TOOTH - 1000 RPM

PARTS LIST				
ITEM	MFG #	PART NUMBER	DESCRIPTION	QTY
1	5730E0384	R22707	#4 1-3/8" CV YOKE - 6 TOOTH SLIDING YOKE COLLAR - 540rpm	1
	5730E3784	R22706	#4 1-3/8" CV YOKE - 21 TOOTH SLIDING YOKE COLLAR - 1000rpm	1
	5730E3884	R22708	#4 1-3/4" CV YOKE - 20 TOOTH SLIDING YOKE COLLAR - 1000rpm	1
2	4120E0051	R22709	#4 CROSS KIT - 22x86mm	2
3	2150E6871	R23381	#4 OUTER TUBE YOKE	1
4	5110E0052	R22711	#4 CENTRAL BODY-CV	1
5	341078000	R23382	FLEXIBLE ROLL PIN - 8x80mm	1
6	2253L1050	R23383	#4 OUTER DRIVE TUBE - L=1050mm	1
7	528S4R121WN	R23384	#4 INNER DRIVE TUBE - L=1075mm	1
8	341048000	R21476	FLEXIBLE ROLL PIN - 8x55mm	1
9	204S46853	R23385	#4 TUBE YOKE 4 LOBE - INNER	1
10	6060E0302	R22712	#4 SHEAR CLUTCH 1700Nm 1-3/8" 6T - PUSH PIN	1
11	4120E0012	R23386	#4 CROSS KIT - 27x74.6mm GREASE ZERK CAP	1
12	2550E0005	R23387	SHIELD OUTER BELL SUPPORT	1
13	2190E0121	R23388	CONE SHIELD BELL - OUTER	1
14	2550C0001	R23389	SHIELD SUPPORT - OUTER TUBE	1
15	5TWN3S4121U	R23390	#4 SHIELD TUBE & CONE - OUTER	1
16	5MWN3S4121U	R23391	#4 SHIELD TUBE & CONE - INNER	1
17	2550C0002	R23392	SHIELD SUPPORT - INNER TUBE	1
18	2190E0201	R23393	CONE SHIELD BELL - INNER	1
19	310001428	R22719	SCREW FLANGE HEAD - SELF TAP 4.8x22mm	6
20	252000050	R21738	SHIELD CHAIN w/ S-HOOK L=500mm	2
21	310001431	R23394	SCREW - SELF TAP 4.8x22mm	6
22	435000323	R22722	BALL COLLAR KIT 1-3/8" 6T & 1-3/8" 21T	1
	435000420	R22723	BALL COLLAR KIT 1-3/4" 20T	1
23	432000047	357-36-00-000	SHEAR BOLT & NUT - 5/PACK	1
23.1	-	R08251	M8x1.25x45 BOLT GR8.8 (NOT FOR INDIVIDUAL SALE)	1
23.2	-	R08252	M8x1.25 NYLOCK NUT (NOT FOR INDIVIDUAL SALE)	1
24	348017000	R21687	GREASE FITTING M6x1 STRAIGHT	1
25	403000001	R22724	COMPLETE PUSH PIN 1-3/8" 6T	1
26	399143000	R21523	DANGER SHIELD MISSING LABEL	1
27	399141000	R21521	DANGER ROTATING DRIVELINE LABEL	1
28	5CS4121U2WSG	R23395	COMPLETE SHIELD KIT	

HUSKY FARM EQUIPMENT LIMITED

ALMA, ON

NOB 1A0

PHONE: (519) 846-5329

FAX: (519) 846-9378

FIVE YEAR AXLE WARRANTY

Husky Farm Equipment Limited will guarantee for five (5) years from date of invoice, all Manure Spreader undercarriages and axle assemblies, if used on a farm for farm purposes.

Husky will replace free of charge:

1. Any part of the axle which should break or collapse through normal use.
2. Any spindles or hubs which should break through normal use.
3. Any wheel and rim assemblies which should fail through normal use.

Exempt from extended warranty are:

1. Any part of the axle which should break or collapse through overload. Overload includes: Any attachments (ie. injectors) and any product being transported in Spreader weighing more than 10 lb/gallon. (ie. manure mixed with sand).
2. Bearings and tires which are covered under normal warranty and do require maintenance to avoid failure.
3. Wheel or rim damage resulting from owner failing to keep wheel bolts tight.
4. Spindles damaged through bearing failure.
5. Any axle that is custom built.
6. Any axle used in commercial custom hauling applications.

To qualify for extended warranty, damaged parts must be returned to Husky Farm Equipment Limited, prepaid shipping, along with serial number and copy of the original invoice.

All parts supplied by Husky on warranty, will be shipped freight collect. Extended warranty covers damaged parts only and does not cause liability on Husky for any damage resulting from such failure.

TEN YEAR WARRANTY AGAINST RUSTOUT

Husky Farm Equipment provides a ten (10) year warranty from date of invoice, against premature perforation (rust out) of any liquid manure spreader manufactured. Providing the manure spreader is used for manure or sludge and not for chemical products.

Extended warranty is pro rated and will be paid only through the crediting off of the then current list price of a replacement manure spreader of the portion of warranty not used up in time.

Warranty will be effective toward replacing spreader only and no cash payment will be made. It will be understood that the original equipment to be replaced will then become property of Husky Farm Equipment Limited.

This extended warranty will be effective through Husky Farm Equipment factory or factory outlet only. A copy of the original invoice is to be supplied along with the serial number. This warranty will not be effective for commercial custom haulers or to owners other than the original.

Transportation to and from the factory is to be paid for by the owner of the equipment and not by Husky Farm Equipment Limited.